



Alltest Instruments, Inc.

500 Central Ave.
Farmingdale, NJ 07727

P: (732) 919-3339
F: (732) 919-3332

alltest.net
sales@alltest.net

The test & measurement equipment you need at the price you want.

Alltest carries the world's largest selection of used/refurbished benchtop test & measurement equipment at 50% the price of new.

Our equipment is guaranteed working, warrantied, and available with certified calibration from our in-house staff of technicians and engineers.

- **10+ full time technicians with over 150 years of specialization**
- **90 day warranty & 5 day right of return on all equipment**
- **1-3 year warranties for new and premium-refurbished equipment**
- **Every unit tested to OEM specifications**
- **Satisfaction guaranteed**

You have plans, we will help you achieve them.
Any project. Any budget.

Get a quote today!

Call (732) 919-3339 or email sales@alltest.net.

Keysight U4203A Direct Connect 34-Channel Single Ended Flying Lead Probe Set

User Guide

Notices

© Keysight Technologies 2014

No part of this manual may be reproduced in any form or by any means (including electronic storage and retrieval or translation into a foreign language) without prior agreement and written consent from Keysight Technologies as governed by United States and international copyright laws.

Manual Part Number

U4203-97000

Edition

First Edition, August 2014

Keysight Technologies.
1900 Garden of the Gods Road
Colorado Springs, CO 80907 USA

Warranty

THE MATERIAL CONTAINED IN THIS DOCUMENT IS PROVIDED "AS IS," AND IS SUBJECT TO BEING CHANGED, WITHOUT NOTICE, IN FUTURE EDITIONS. FURTHER, TO THE MAXIMUM EXTENT PERMITTED BY APPLICABLE LAW, KEYSIGHT DISCLAIMS ALL WARRANTIES, EITHER EXPRESS OR IMPLIED WITH REGARD TO THIS MANUAL AND ANY INFORMATION CONTAINED HEREIN, INCLUDING BUT NOT LIMITED TO THE IMPLIED WARRANTIES OF MERCHANTABILITY AND FITNESS FOR A PARTICULAR PURPOSE. KEYSIGHT SHALL NOT BE LIABLE FOR ERRORS OR FOR INCIDENTAL OR CONSEQUENTIAL DAMAGES IN CONNECTION WITH THE FURNISHING, USE, OR PERFORMANCE OF THIS DOCUMENT OR ANY INFORMATION CONTAINED HEREIN. SHOULD KEYSIGHT AND THE USER HAVE A SEPARATE WRITTEN AGREEMENT WITH WARRANTY TERMS COVERING THE MATERIAL IN THIS DOCUMENT THAT CONFLICT WITH THESE

TERMS, THE WARRANTY TERMS IN THE SEPARATE AGREEMENT WILL CONTROL.

Technology Licenses

The hardware and/or software described in this document are furnished under a license and may be used or copied only in accordance with the terms of such license.

Restricted Rights Legend

If software is for use in the performance of a U.S. Government prime contract or sub-contract, Software is delivered and licensed as "Commercial computer software" as defined in DFAR 252.227-7014 (June 1995), or as a "commercial item" as defined in FAR 2.101(a) or as "Restricted computer software" as defined in FAR 52.227-19 (June 1987) or any equivalent agency regulation or contract clause. Use, duplication or disclosure of Software is subject to Keysight Technologies standard commercial license terms, and non-DOD Departments and Agencies of the U.S. Government will receive no greater than Restricted Rights as defined in FAR 52.227-19(c)(1-2) (June 1987). U.S. Government users will receive no greater than Limited Rights as defined in FAR 52.227-14 (June 1987) or DFAR 252.227-7015 (b)(2) (November 1995), as applicable in any technical data.

Safety Notices

CAUTION

A CAUTION notice denotes a hazard. It calls attention to an operating procedure, practice, or the like that, if not correctly performed or adhered to, could result in damage to the product or loss of important data. Do not proceed beyond a CAUTION notice until the indicated conditions are fully understood and met.

WARNING

A WARNING notice denotes a hazard. It calls attention to an operating procedure, practice, or the like that, if not correctly performed or adhered to, could result in personal injury or death. Do not proceed beyond a WARNING notice until the indicated conditions are fully understood and met.

Contents

1 General Information

To inspect the probe	7
Accessories	9
Characteristics and Specifications	11
General Characteristics	12
To connect and set up the probe set	14

2 Operating the Probe

Introduction	18
Suggested Configurations and Characteristics	18
130 ohm Resistive Signal Pin (orange) and Solder-down Ground Lead	20
Input Impedance	20
Time Domain Transmission (TDT)	22
Step Inputs	26
Eye Opening	30
5 cm Resistive Signal Lead and Solder-down Ground Lead	35
Input Impedance	36
Time Domain Transmission (TDT)	39
Step Input	42
Eye Opening	46

Flying Lead and Ground Extender	49
Input Impedance	49
Time Domain Transmission (TDT)	51
Step Input	54
Eye Opening	57
Grabber Clip and Right-angle Ground Lead	61
Input Impedance	61
Time Domain Transmission (TDT)	63
Step Input	66
Eye Opening	69
Connecting to Coaxial Connectors	73
Combining Grounds	76

Safety Information

Safety Symbols	78
Informations relatives à la sécurité	81
Symboles de sécurité:	82

Keysight U4203A Direct Connect 34-Channel
Single Ended Flying Lead Probe Set

User Guide

1

General Information

To inspect the probe / 7
Accessories / 9
Characteristics and Specifications / 11
General Characteristics / 12
To connect and set up the probe set / 14

The U4203A is a 34-channel single-ended flying lead probe set which is compatible with the 160-pin interface on logic analyzers including the Keysight 16850-series portable logic analyzers and U4154A logic analysis AXIe-based modules. The U4203A enables you to acquire signals from randomly located points in your target system.

Examples - One U4203A is required to support all 34 channels of one 16851A, two U4203As for all 68 channels of a 16852A, three U4203As for all 102 channels of a 16853A, and four U4203As for all 136 channels of a 16854A.

A variety of accessories are supplied with the U4203A, to access signals on various types of components on your PC board.

NOTE

U4203A is a 'Direct Connect' cable. Therefore, U4201A flat ribbon cable is not required to connect to the 16850-series logic analyzer.

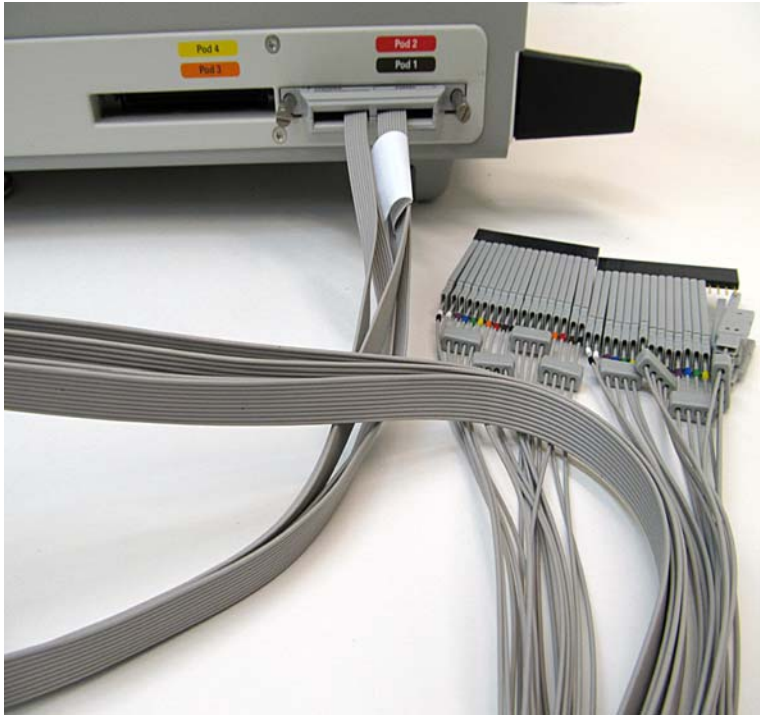

Figure 1 Single-ended flying lead probe set.

To inspect the probe

1 Inspect the shipping container for damage.

Keep a damaged shipping container or cushioning material until the contents of the shipment have been checked for completeness and the instrument has been checked mechanically and electrically.

2 Check the accessories.

Accessories supplied with the instrument are listed in "Accessories Supplied" later in this chapter.

- If the contents are incomplete or damaged, notify your Keysight Technologies Sales Office.

3 Inspect the probe.

If there is a mechanical damage or defect, or if the probe does not operate properly or pass performance tests, notify your Keysight Technologies Sales Office.

If the shipping container is damaged, or the cushioning materials show signs of stress, notify the carrier as well as your Keysight Technologies Sales Office. Keep the shipping materials for the carrier's inspection.

The Keysight Technologies Office will arrange for repair or replacement at Keysight Technologies' option without waiting for claim settlement.

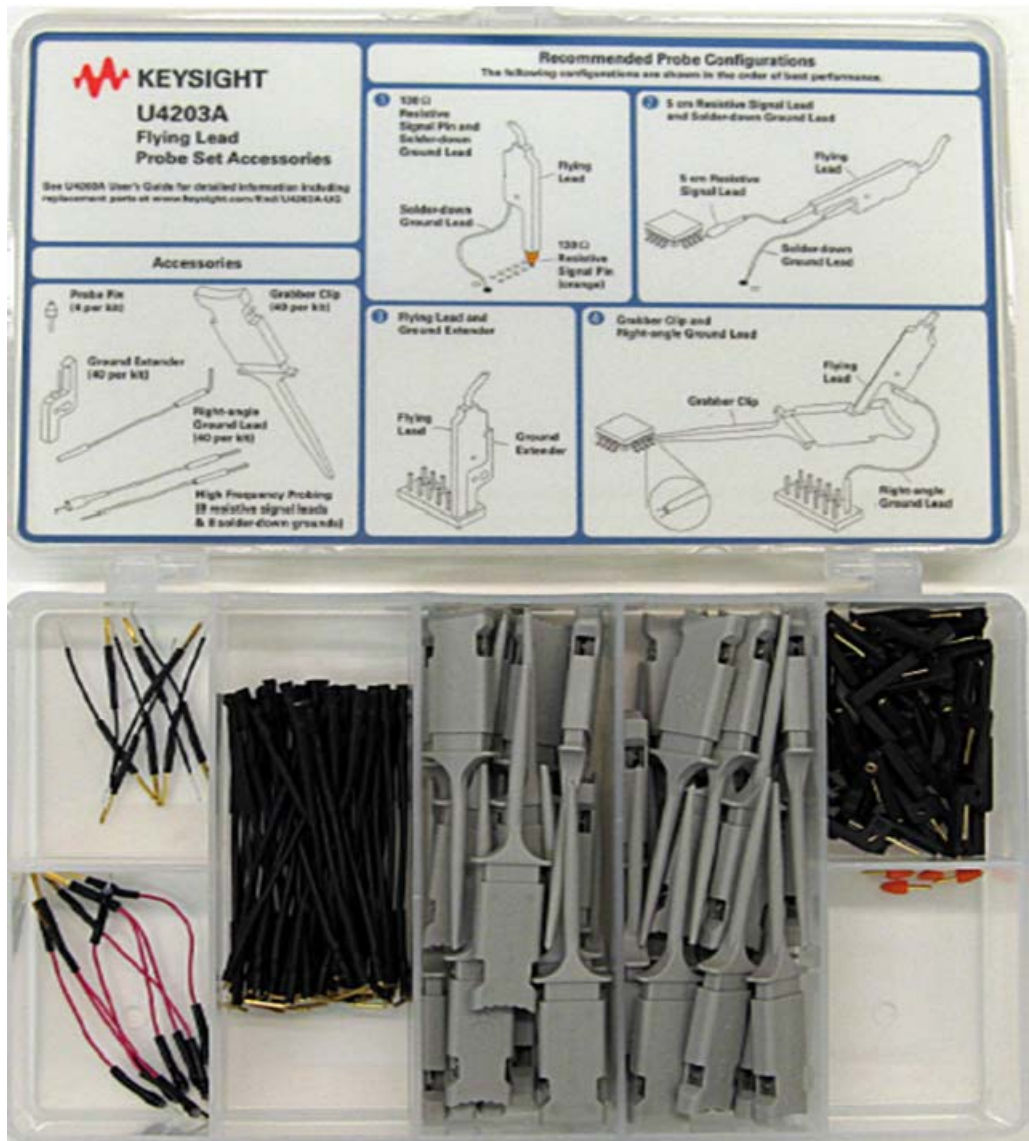

Figure 2 Probe accessories case contents

Accessories

The following figure shows the accessories supplied with the U4203A Single-ended Flying Lead Probe.

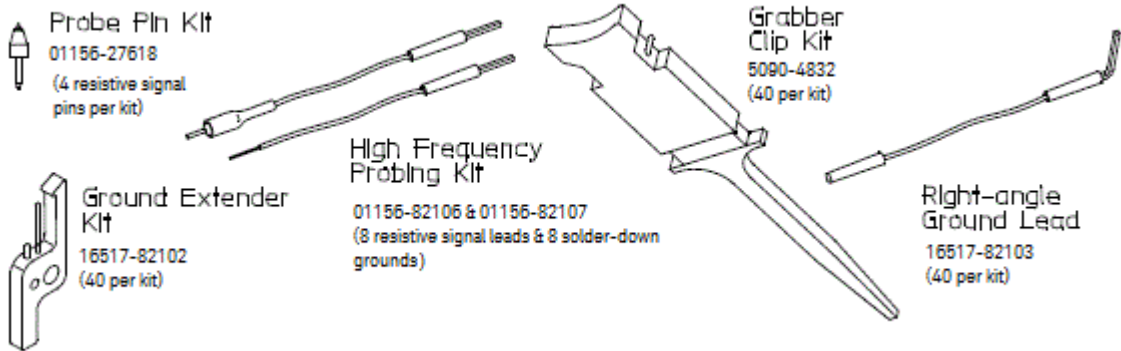

Figure 3 Accessories supplied

The replacement parts and additional accessories can be ordered as a full accessory kit (part number U4203-68702).

The following table lists the part numbers for ordering replacement parts and additional accessories.

U4203-68702 Replaceable Parts and Additional Accessories

Description	Accessories Part Number	Orderable Keysight Part Numbers	Qty
Probe Pin Kit	01156-27618	E5382-82103	a set of 2
High Frequency Probing Kit: <ul style="list-style-type: none"> • Resistive signal pins • Solder-down grounds 	01156-82106 01156-82107	E5382-82101	a set of 4 each a set of 4 each
Ground Extender Kit	16517-82102	16517-82105	a set of 20
Grabber Clip Kit	5090-4832	16517-82109	a set of 20
Right-angle Ground Lead Kit	16517-82103	16517-82106	a set of 20
Cable - Main	U4203-60001	U4203-60001	1
Probe Tip to BNC Adapter	E9638A	E9638A	1

Characteristics and Specifications

The following characteristics are typical for the probe set.

Characteristics

Input Resistance	20 k Ω
Input Capacitance	1.3 pF (accessory-specific, see accessories)
Maximum Recommended State Data Rate	1.5 Gb/s (accessory-specific, see accessories)
Minimum Data Voltage Swing	250 mV p-p
Minimum Diff. Clock Voltage Swing	100 mV p-p each side
Input Dynamic Range	-3 Vdc to +5 Vdc
Threshold Accuracy	$\pm(30 \text{ mV} + 2\% \text{ of setting})$
Threshold Range	-3.0 V to +5.0 V
Maximum Nondestructive Input Voltage	40 Vdc
Maximum Input Slew Rate	5 V/ns
Clock Input	differential ⁽²⁾
Number of Inputs ⁽¹⁾	17 (1 clock and 16 data)

⁽¹⁾ refer to specifications on specific modes of operation for details on how inputs can be used

⁽²⁾ if using the clock as single-ended, the unused clock input must be grounded and the minimum voltage swing for single-ended clock operation is 250mV p-p

General Characteristics

The following general characteristics apply to the probe set.

Environmental Conditions

	Operating	Non-operating
Temperature	0 °C to +55 °C	-40 °C to +70 °C
Humidity	up to 95% relative humidity (non-condensing) at +40 °C	up to 90% relative humidity at +65 °C
Weight	approximately 0.69 kg	
Dimensions	Refer to the figure below.	
Pollution degree 2	Normally only non-conductive pollution occurs. Occasionally, however, a temporary conductivity caused by condensation must be expected.	
Indoor use		

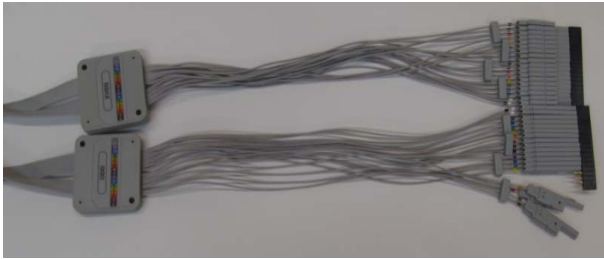
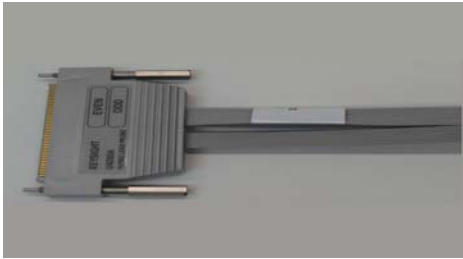
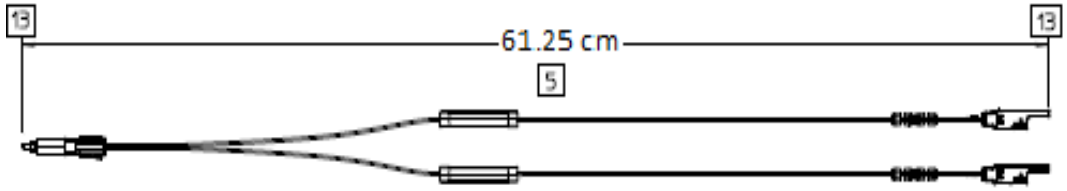

Figure 4 U4302A Single-ended Flying Lead Probe Dimensions

To connect and set up the probe set

- 1 Connect the single-ended probe to the logic analysis module or to the portable logic analyzer side connector.

One U4203A is required to support all 34 channels of one 16851A, two U4203A's for all 68 channels of a 16852A, three U4203A's for all 102 channels of a 16853A, and four U4203A's for all 136 channels of a 16854A.

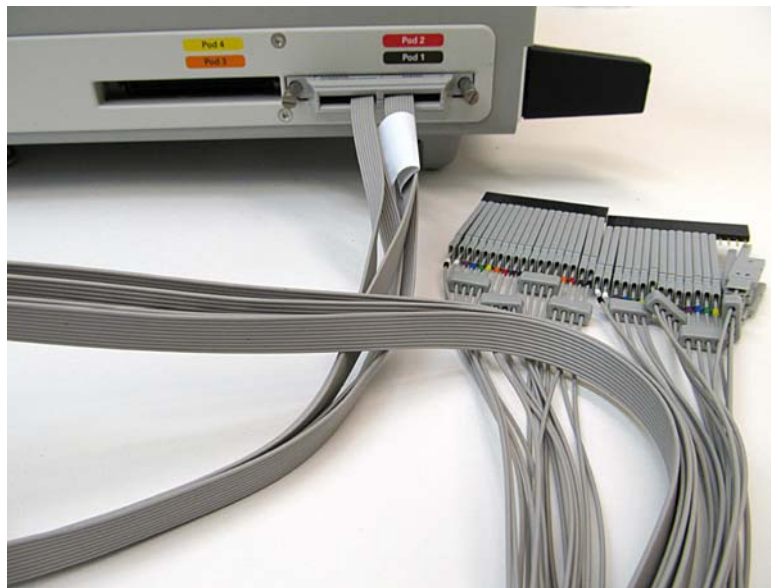

Figure 5 Probe set connected to portable logic analyzer

- 2 Set the clock input.
 - a If you are using a differential clock, select the Clock Threshold button in the analyzer setup screen of the logic analyzer.

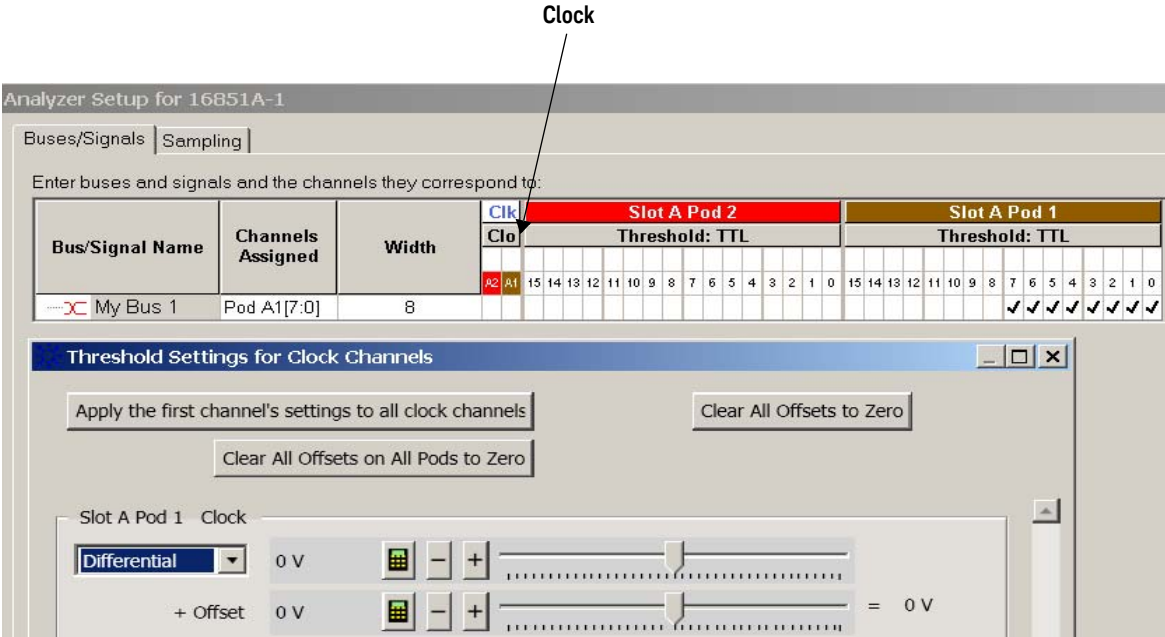

Figure 6 Differential threshold

- b If your clock is not differential, ground the unused clock input and set the threshold to the desired level.

Keysight U4203A Direct Connect 34-Channel
Single Ended Flying Lead Probe Set

User Guide

2 Operating the Probe

Introduction / 18

130 ohm Resistive Signal Pin (orange) and Solder-down Ground Lead / 20

5 cm Resistive Signal Lead and Solder-down Ground Lead / 35

Flying Lead and Ground Extender / 49

Grabber Clip and Right-angle Ground Lead / 61

Grabber Clip and Right-angle Ground Lead / 61

Connecting to Coaxial Connectors / 73

Combining Grounds / 76

This chapter describes the recommended probe configurations in the order of best performance. Select the configuration that works with your target system.

Introduction

The Keysight U4203A single-ended flying lead probe set comes with accessories that trade off flexibility, ease of use, and performance. Discussion and comparisons between four of the most common intended uses of the accessories are included in this chapter. The table that follows is an overview of the trade-offs between the various accessories. Each of the four configurations have been characterized for probe loading effects, probe step response, and maximum usable state speed. For more detailed information, refer to the pages indicated for each configuration.

When simulating circuits that include a load model for the probe, a simplified model of the probe's input impedance can usually be used. The following table contains information for the simplified model of the probe using suggested accessory configurations. For more accurate load models and detailed discussion of each configuration's performance, refer to the pages indicated.

Suggested Configurations and Characteristics

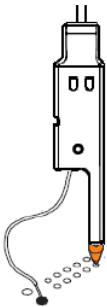
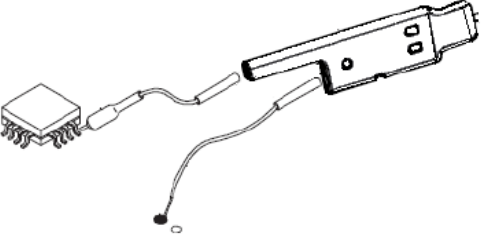
	130 Ω Resistive Signal Pin (orange) and Solder-down Ground Lead	1.3 pF	1.5 Gb/s	page 20
	5 cm Resistive Signal Lead and Solder-down Ground Lead	1.6 pF	1.5 Gb/s	page 35

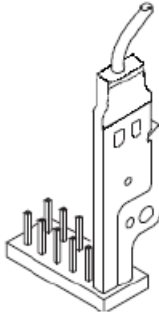
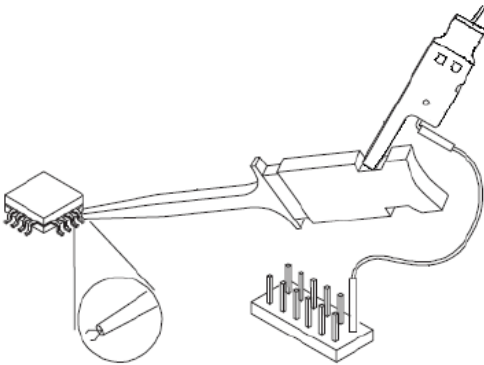
	Flying Lead and Ground Extender	1.4 pF	1.5 Gb/s	page 49
	Grabber Clip and Right-angle Ground Lead	2.0 pF	600 Mb/s	page 61

130 ohm Resistive Signal Pin (orange) and Solder-down Ground Lead

This configuration is recommended for hand-held probing of individual test points. Use the resistive signal pin for the signal. For the ground, the preferred method is to use the solder-down ground lead. Alternatively, for ground you could use the right-angle ground lead and a grabber clip as shown on [page 61](#).

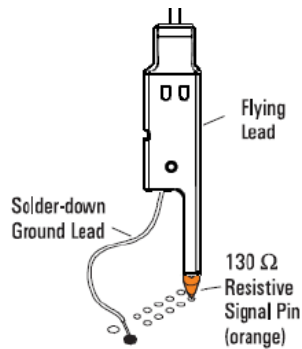

Figure 8 Hand-held probing configuration

The 130 Ω resistive signal pin and solder-down ground leads are identical to the accessories for the Keysight 1156A/57A/58A series oscilloscope probes. They provide similar loading effects and characteristics. The accessories for the 1156A/57A/58A probes are compatible with the E5382 B probes allowing you to interchange scope and logic analyzer leads.

Input Impedance

The U4203A probes have an input impedance which varies with frequency, and depends on which accessories are being used. The following schematic shows the circuit model for the input impedance of the probe when using the 130 Ω resistive signal pin (orange) and the solder-down

ground wire. This model is a simplified equivalent load of the measured input impedance seen by the target.

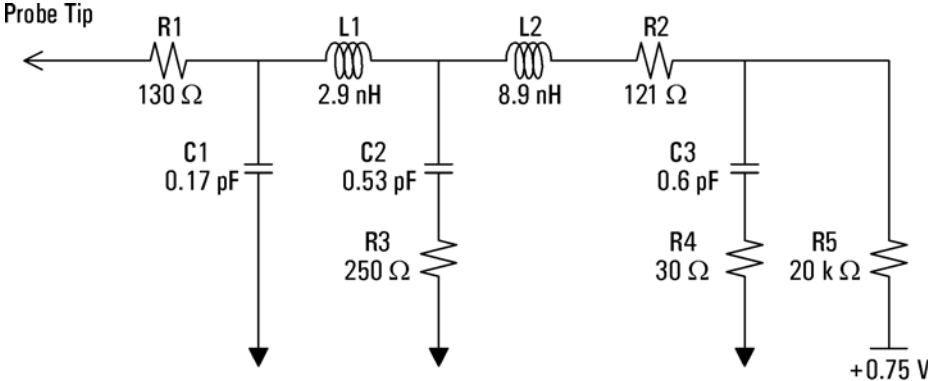

Figure 9 Equivalent load model

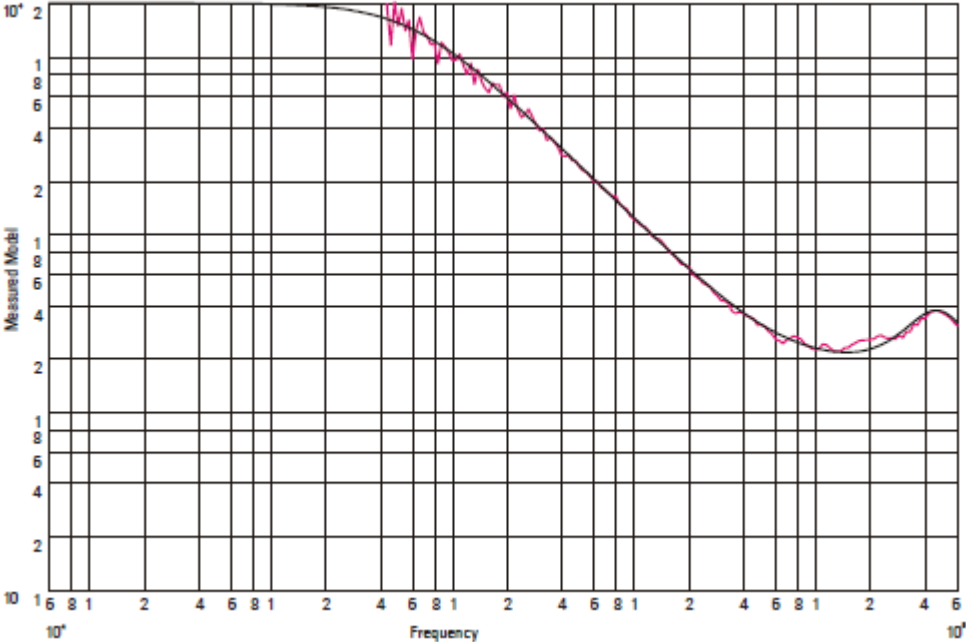

Figure 10 Measured versus modeled input impedance

Time Domain Transmission (TDT)

All probes have a loading effect on the circuit when they come in contact with the circuit. Time domain transmission (TDT) measurements are useful for understanding the probe loading effects as seen at the target receiver. The following TDT measurements were made mid-bus on a $50\ \Omega$ transmission line load terminated at the receiver. These measurements show how the $130\ \Omega$ resistive signal pin (orange) and solder-down ground lead configuration affect the step seen by the receiver for various rise times.

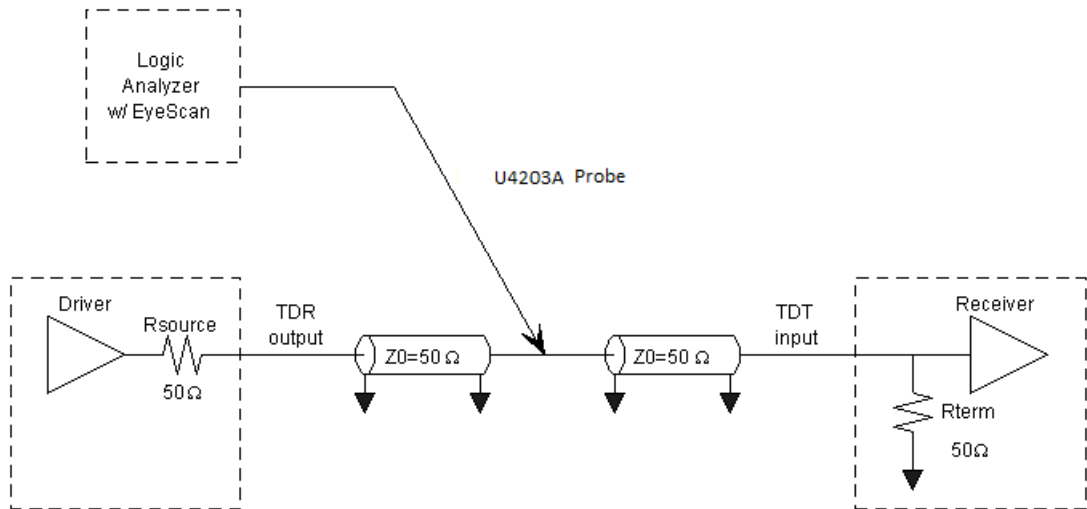

Figure 11 TDT measurement schematic

As the following graphs demonstrate, the $130\ \Omega$ resistive signal pin and solder-down ground lead configuration is the least intrusive of the four recommended configurations. The graphs show that the loading effects are virtually invisible for targets with rise times ≥ 500 ps, negligible for targets with 250 ps rise times, and usable for 100 ps rise times. Ultimately, you must determine what is an acceptable amount of distortion of the target signal.

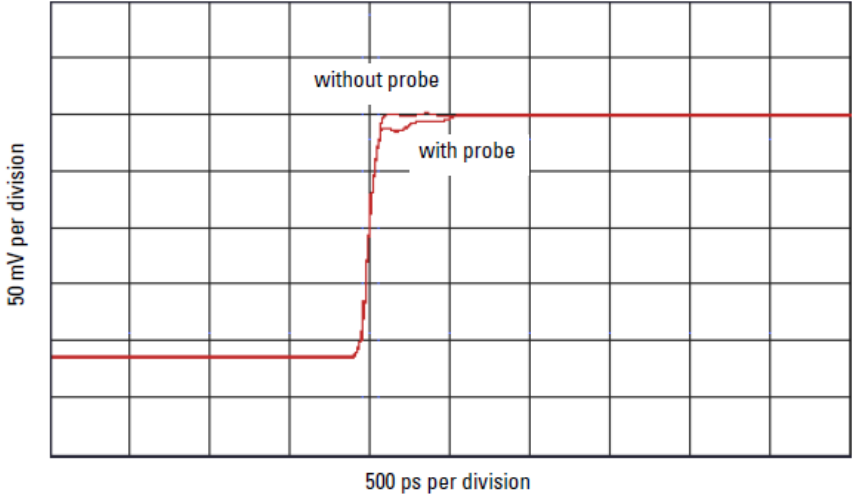

Figure 12 TDT measurement at receiver with and without probe load for 100 ps rise time

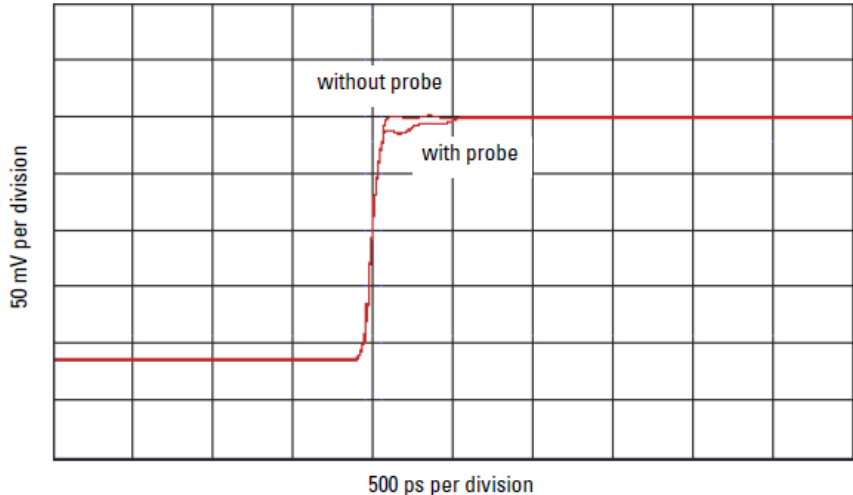

Figure 13 TDT measurement at receiver with and without probe load for 250 ps rise time

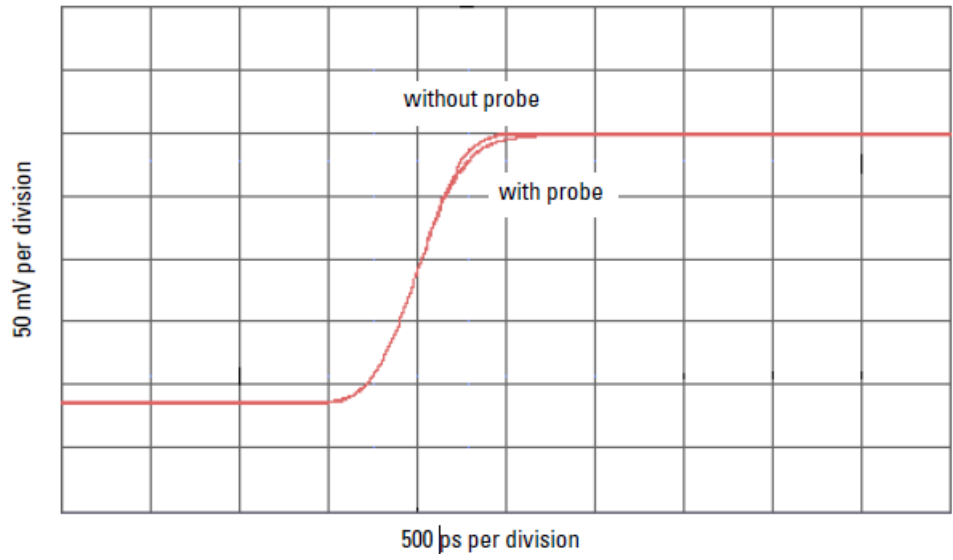

Figure 14 TDT measurement at receiver with and without probe load for 500 ps rise time

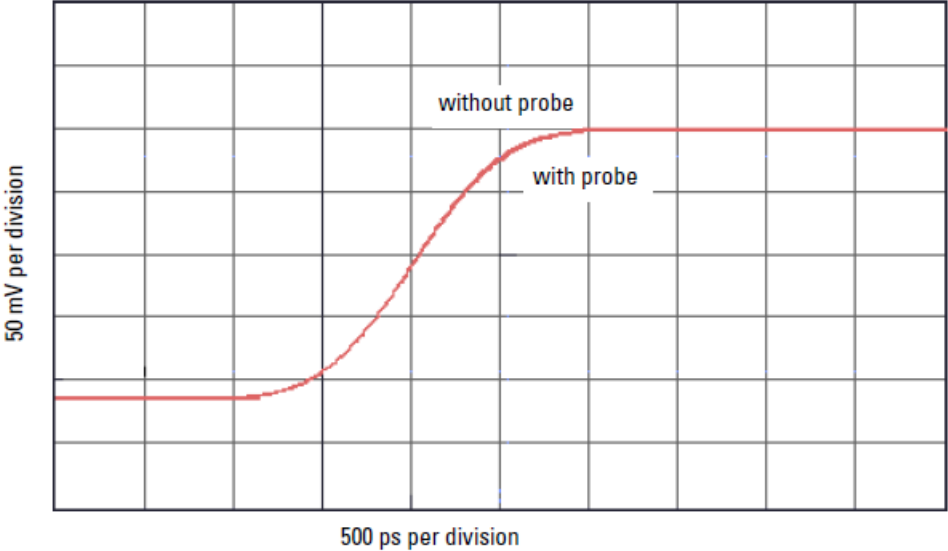

Figure 15 TDT measurement at receiver with and without probe load for 1 ns rise time

Step Inputs

Maintaining signal fidelity to the logic analyzer is critical if the analyzer is to accurately capture data. One measure of a system's signal fidelity is to compare V_{in} to V_{out} for various step inputs. For the following graphs, V_{in} is the signal at the logic analyzer probe tip measured by double probing with Keysight 54701A probe into Keysight 54750A oscilloscope (total 2.5 GHz BW). Eye Scan is used to measure V_{out} , the signal seen by the logic analyzer. The measurements were made on a mid-bus connection to a 50 Ω transmission line load_terminated at the receiver. These measurements show the logic analyzer's response while using the 130 Ω resistive signal pin (orange) and solder-down ground lead configuration.

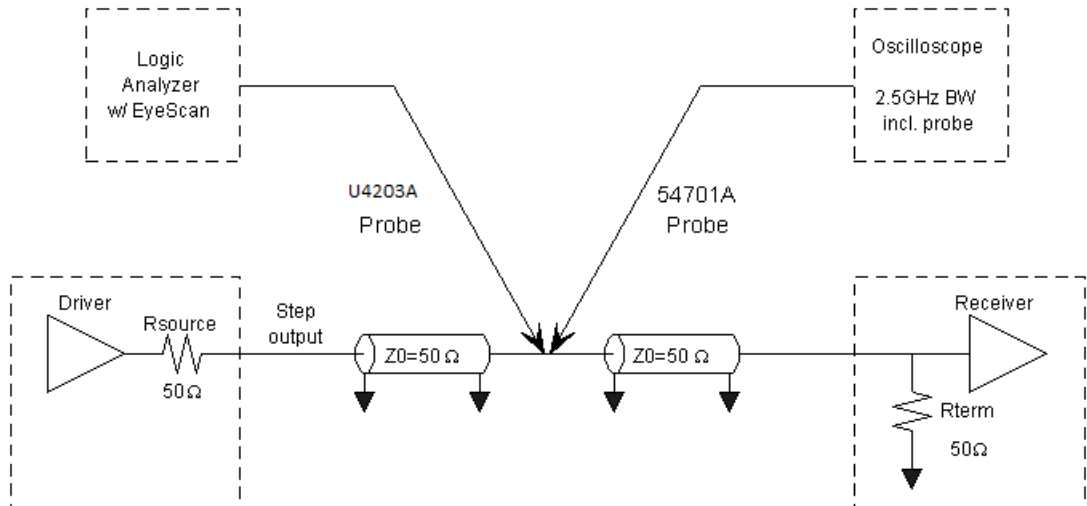

Figure 16 Step input measurement schematic

The following graphs demonstrate the logic analyzer's probe response to different rise times. These graphs are included for you to gain insight into the expected performance of the different recommended configurations.

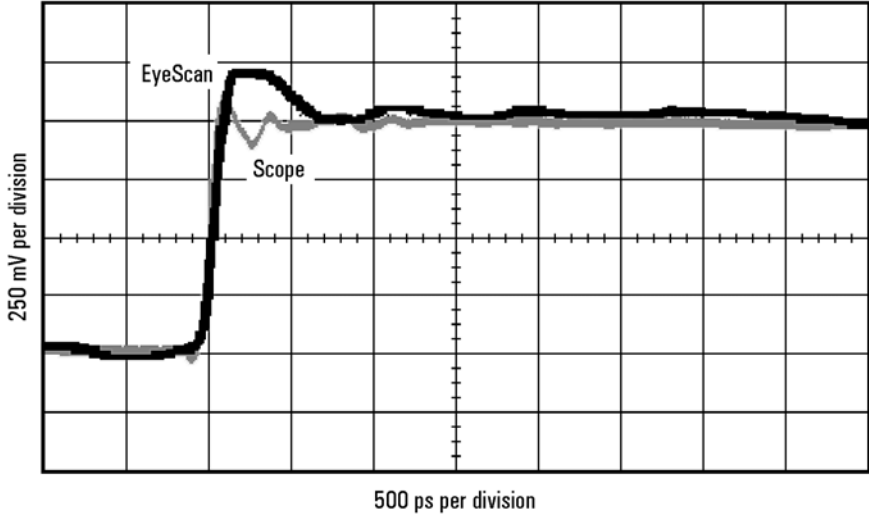

Figure 17 Logic analyzer's response to a 100 ps rise time

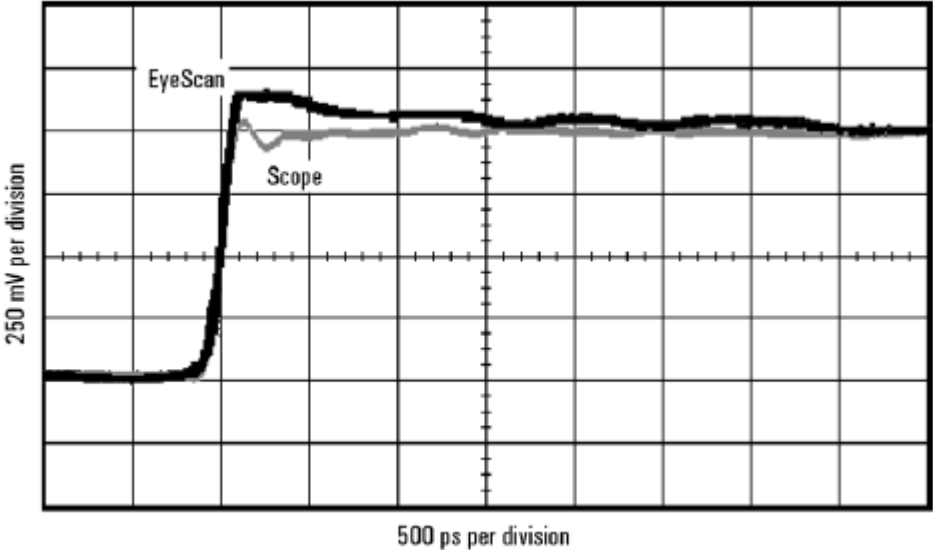

Figure 18 Logic analyzer's response to a 250 ps rise time

NOTE

These measurements are not the true step response of the probes. The true step response of a probe is the output of the probe while the input is a perfect step.

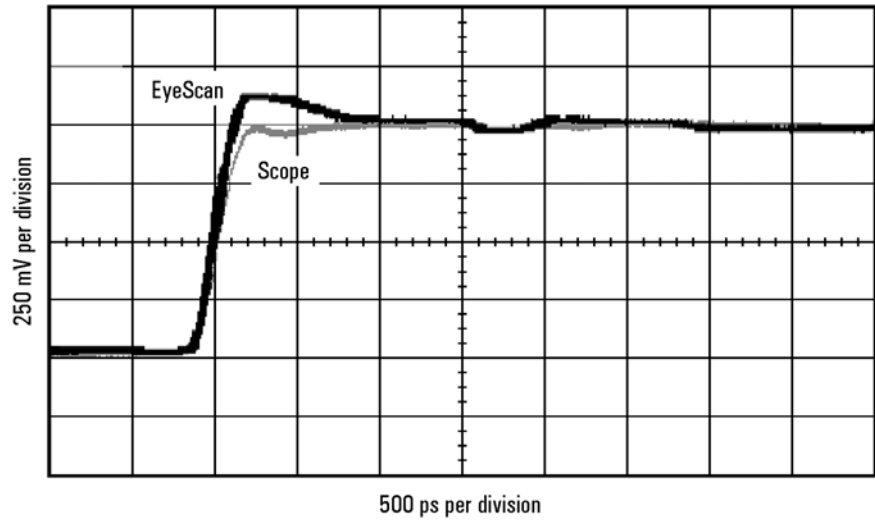

Figure 19 Logic analyzer's response to a 500 ps rise time

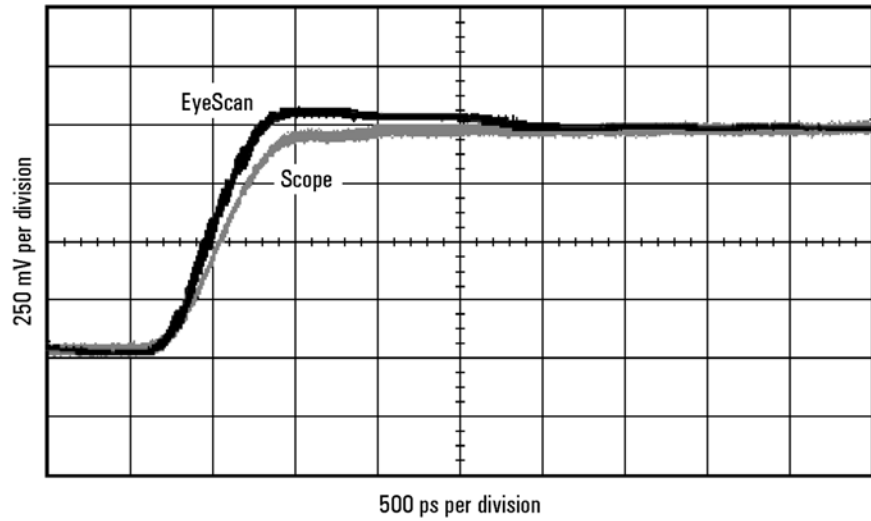

Figure 20 Logic analyzer's response to a 1 ns rise time

NOTE

These measurements are not the true step response of the probes. The true step response of a probe is the output of the probe while the input is a perfect step.

Eye Opening

The eye opening at the logic analyzer is the truest measure of an analyzer's ability to accurately capture data. Seeing the eye opening at the logic analyzer is possible with Eye Scan. Eye opening helps you know how much margin the logic analyzer has, where to sample and at what threshold. Any probe response that exhibits overshoot and ringing, probe non-flatness, noise and other issues all deteriorate the eye opening seen by the logic analyzer. The following eye diagrams were measured using Eye Scan probed mid-bus on a $50\ \Omega$ transmission line load terminated at the receiver. The data patterns were generated using a $2^{23}-1$ pseudo random bit sequence (PRBS). These measurements show the remaining eye opening at the logic analyzer while using the $130\ \Omega$ resistive signal pin (orange) and solder-down ground lead configuration.

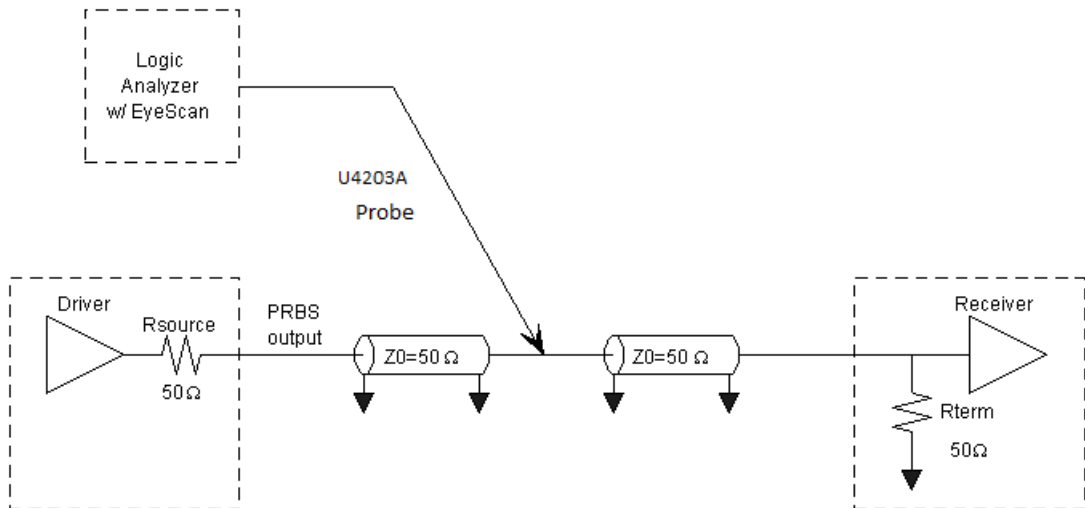

Figure 21 Eye opening measurement schematic

The logic analyzer Eye Scan measurement uses the same circuitry as the synchronous state mode analysis. Therefore, the eye openings measured are exact representations of what the logic analyzer sees and operates on in state mode. The following measurements demonstrate how the eye opening starts to collapse as the clock rate is increased. At $1500\ \text{Mb/s}$, the eye opening is noticeably deteriorating as jitter on the transitions increase and voltage margins decrease. As demonstrated by the last eye diagram, the $130\ \Omega$ resistive signal pin and solder-down ground lead configuration still has a usable eye opening at $1250\ \text{Mb/s}$ and minimum signal swing.

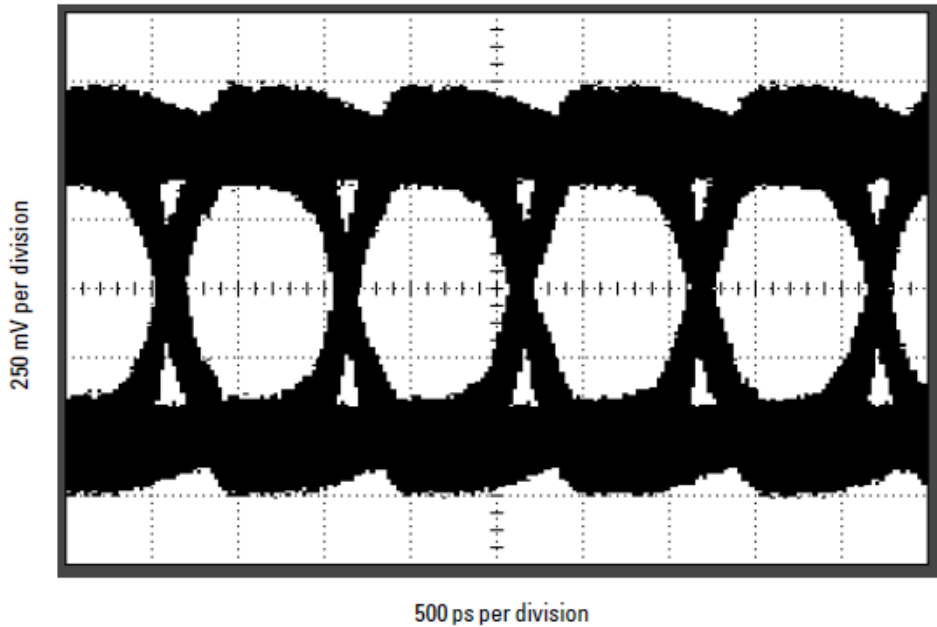

Figure 22 Logic analyzer eye opening for a PRBS signal of 1 V p-p, 1000 Mb/s data rate

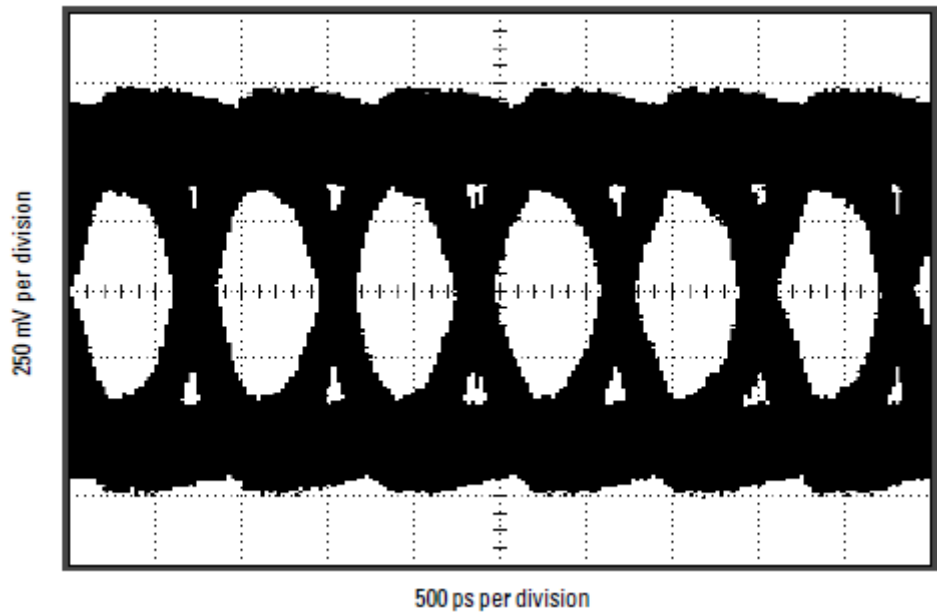

Figure 23 Logic analyzer eye opening for a PRBS signal of 1 V p-p, 1250 Mb/s data rate

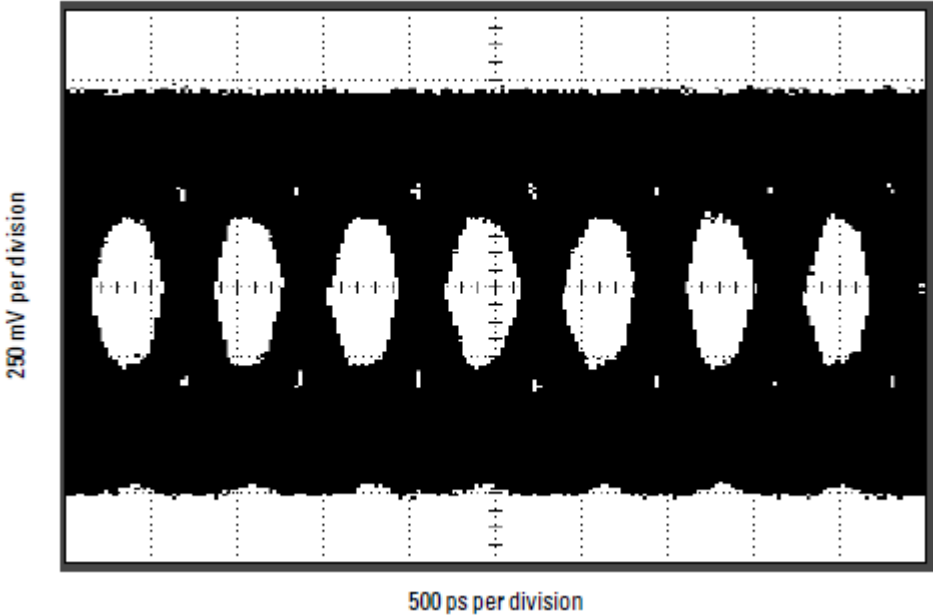

Figure 24 Logic analyzer eye opening for a PRBS signal of 1 V p-p, 1500 Mb/s data rate

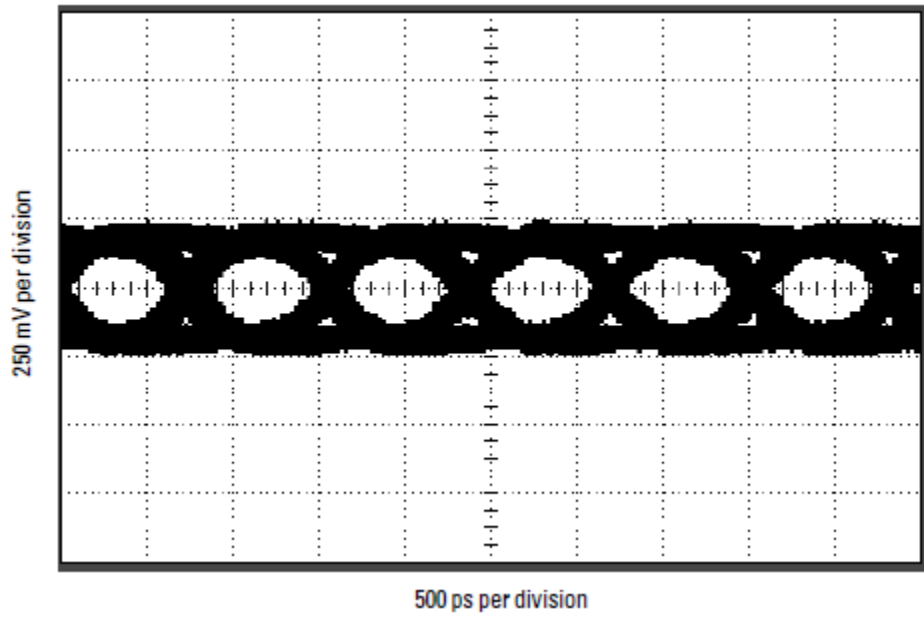

Figure 25 Logic analyzer eye opening for a PRBS signal of 250 mV, 1250 Mb/s data rate

5 cm Resistive Signal Lead and Solder-down Ground Lead

This configuration is recommended for accessing components such as IC leads or surface-mount component leads for hands-off probing.

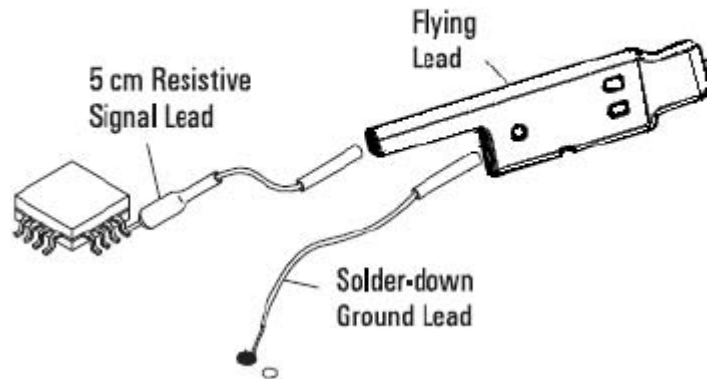

Figure 26 Surface-mount probe configuration

CAUTION

The resistor bends easily. A bent resistor could affect the performance of the 5 cm resistive signal lead.

The 5cm resistive signal lead and the solder-down ground leads are identical to the accessories for the Keysight 1156A/57A/58A oscilloscope probes. They provide similar loading effects and characteristics. The accessories for the 1156A/57A/58A oscilloscope probes are compatible with the U4203A probes, allowing you to interchange scope and logic analyzer leads.

Input Impedance

The U4203A probes have an input impedance which varies with frequency, and depends on which accessories are being used. The following schematic shows the circuit model for the input impedance of the probe when using the SMT solder-down Signal (red) and Ground (black) wires. This model is a simplified equivalent load of the measured input impedance seen by the target.

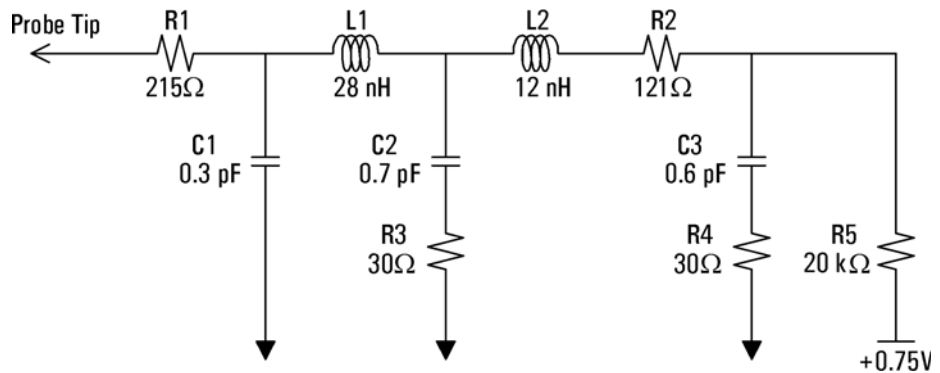

Figure 27 Equivalent load model

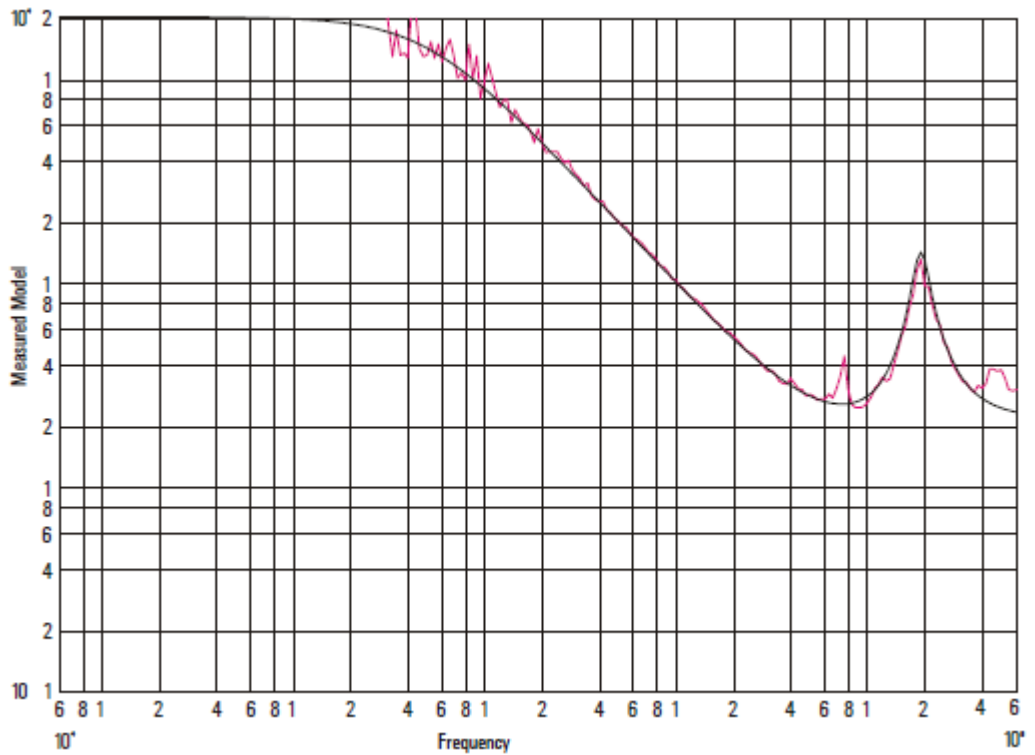

Figure 28 Measured versus modeled input impedance

Other signal lead lengths may be used with these probes but a resistance value needs to be determined from the following figure and a resistor of that value needs to be placed as close as possible to the point being probed.

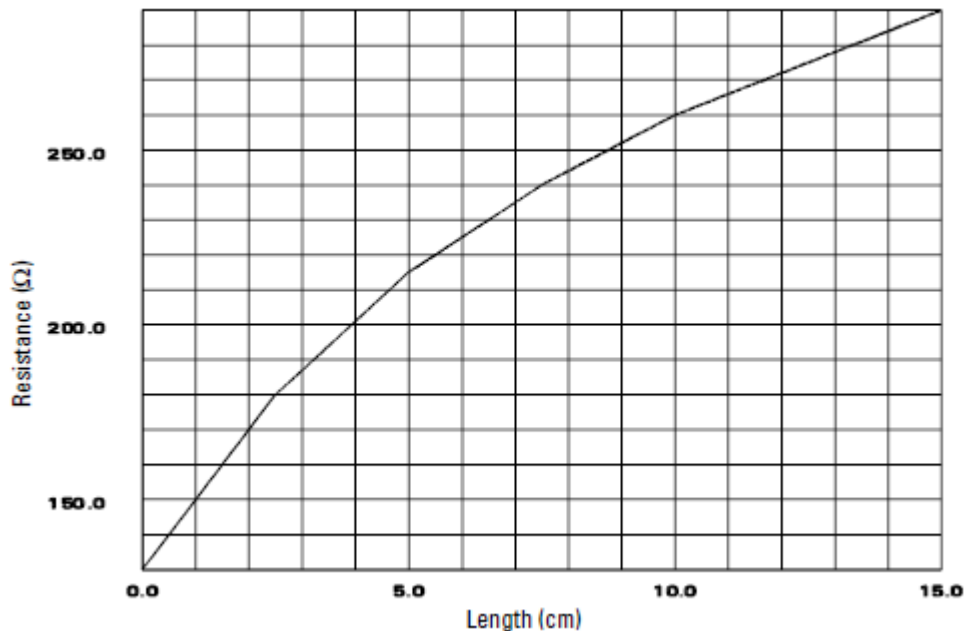

Figure 29 Optimum Damping Resistor Value Versus Signal Lead Length

If a resistor is not used, the response of the probe will be very peaked at high frequencies. This will cause overshoot and ringing to be introduced in the step response of waveforms with fast rise times. Use of this probe without a resistor at the point being probed should be limited to measuring only waveforms with slower rise times.

Time Domain Transmission (TDT)

All probes have a loading effect on the circuit when they come in contact with the circuit. Time domain transmission (TDT) measurements are useful for understanding the probe loading effects as seen at the target receiver. The following TDT measurements were made mid-bus on a $50\ \Omega$ transmission line load terminated at the receiver. These measurements show how the 5 cm resistive signal lead and solder-down ground lead configuration affect the step seen by the receiver for various rise times.

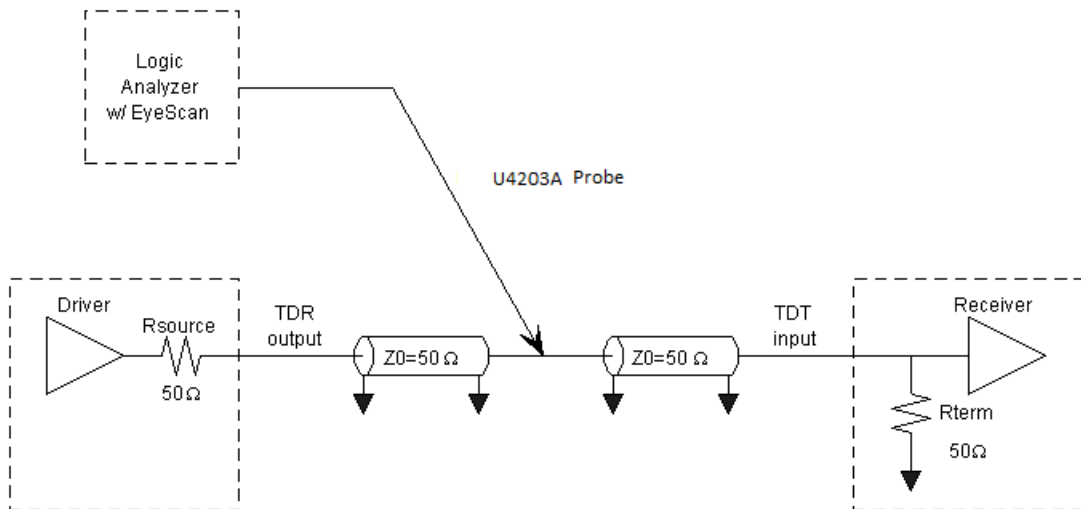

Figure 30 TDT measurement schematic

The recommended configurations are listed in order of loading on the target. As the following graphs demonstrate, the 5 cm resistive signal lead and solder-down ground lead configuration has the 2nd best loading of the four recommended configurations. The graphs show that the loading effects are virtually invisible for targets with rise times ≥ 500 ps, negligible for targets with 250 ps rise times, and probably still acceptable for 100 ps rise times. Ultimately, you must determine what is an acceptable amount of distortion of the target signal.

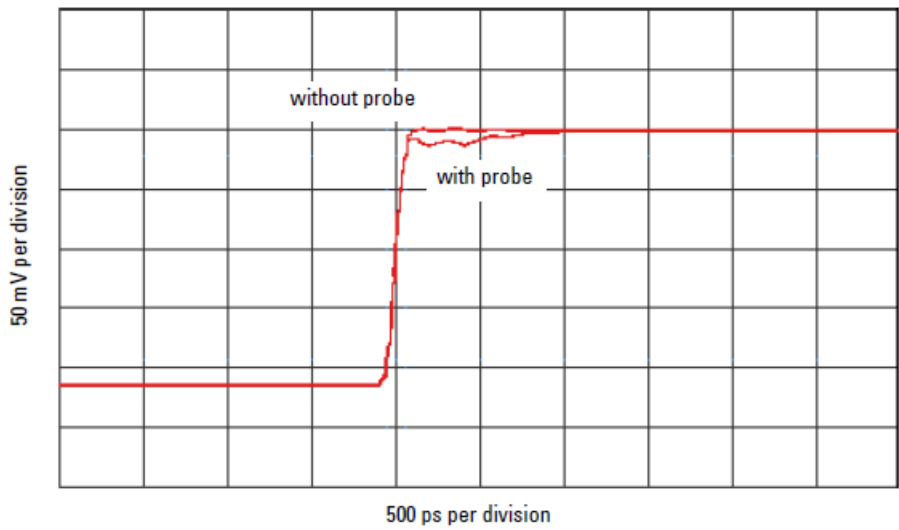

Figure 31 TDT measurement at receiver with and without probe load for 100 ps rise time

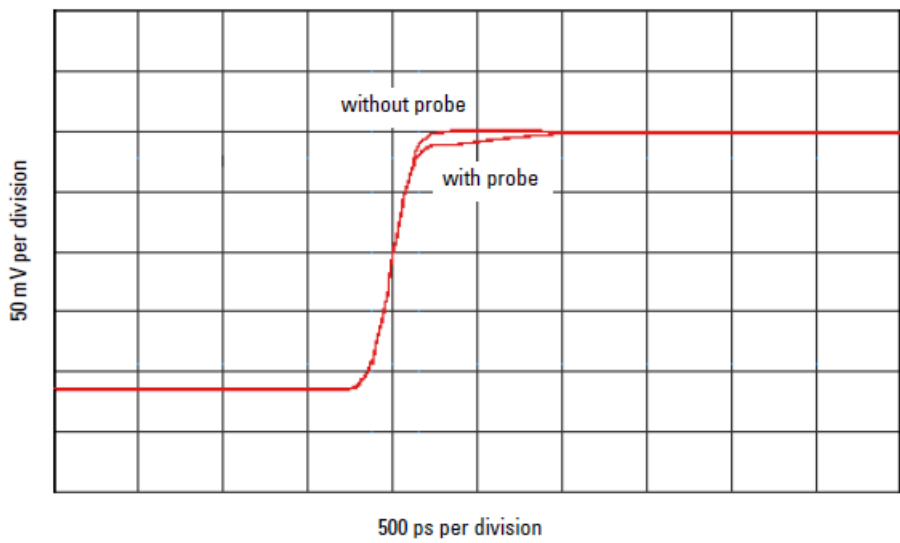

Figure 32 TDT measurement at receiver with and without probe load for 250 ps rise time

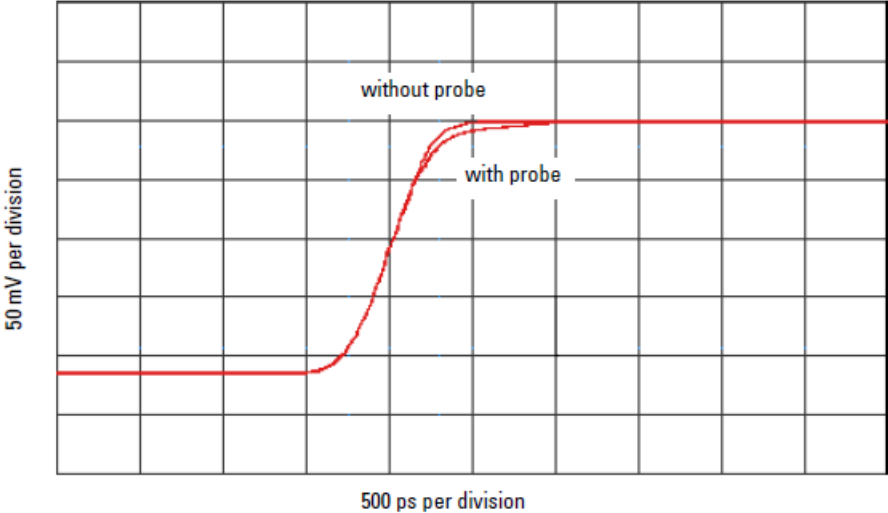

Figure 33 TDT measurement at receiver with and without probe load for 500 ps rise time

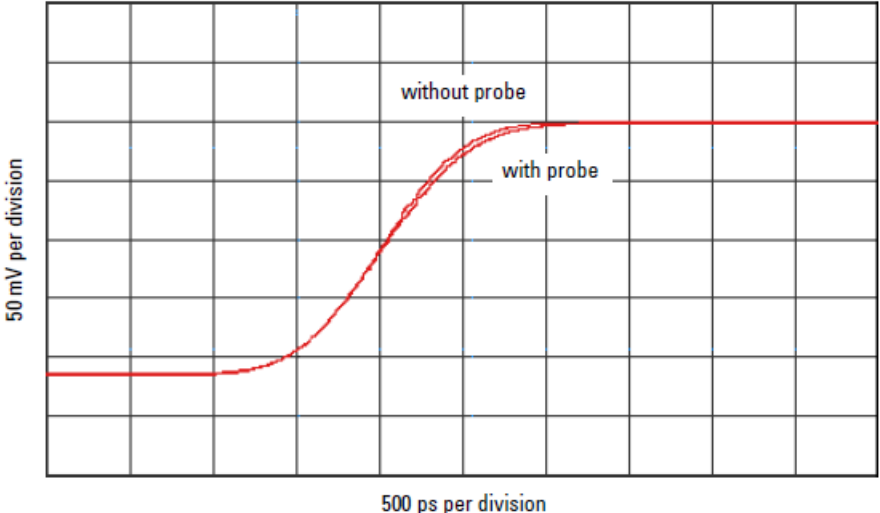

Figure 34 TDT measurement at receiver with and without probe load for 1 ns rise time

Step Input

Maintaining signal fidelity to the logic analyzer is critical if the analyzer is to accurately capture data. One measure of a system's signal fidelity is to compare V_{in} to V_{out} for various step inputs. For the following graphs, V_{in} is the signal at the logic analyzer probe tip measured by double probing with Keysight 54701A probe into Keysight 54750A oscilloscope (total 2.5 GHz BW). Eye Scan is used to measure V_{out} , the signal seen by the logic analyzer. The measurements were made on a mid-bus connection to a 50 Ω transmission line load terminated at the receiver. These measurements show the logic analyzer's response while using the 5 cm resistive signal lead and solder-down ground lead configuration.

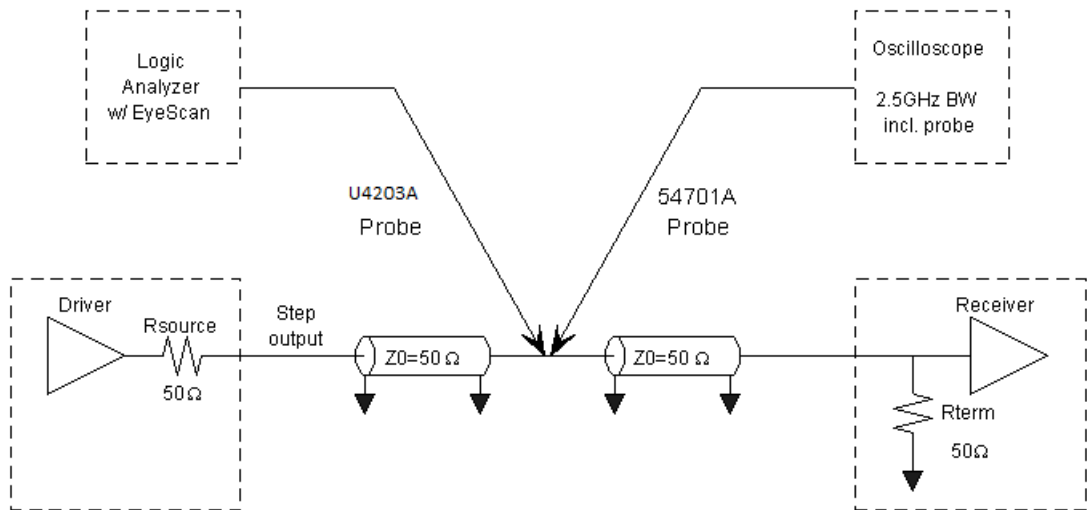

Figure 35 Step input measurement schematic

The following graphs demonstrate the logic analyzer's probe response to different rise times. These graphs are included for you to gain insight into the expected performance of the different recommended configurations.

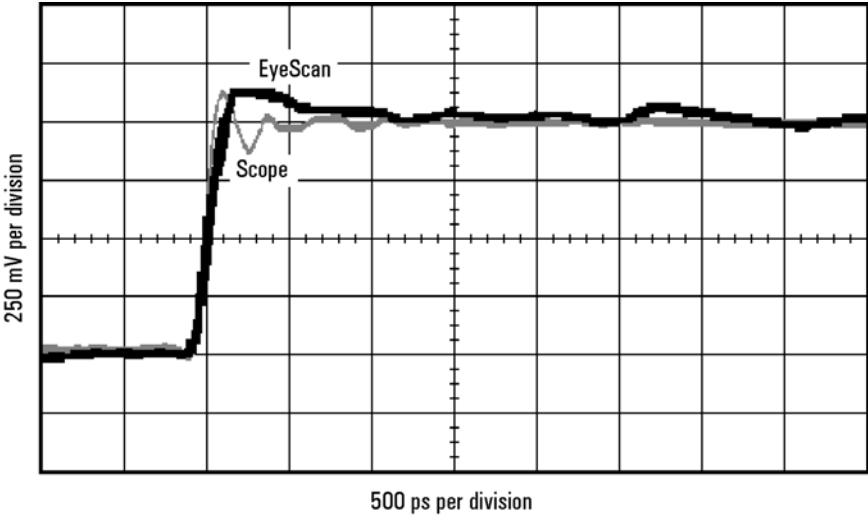

Figure 36 Logic analyzer's response to a 100 ps rise time

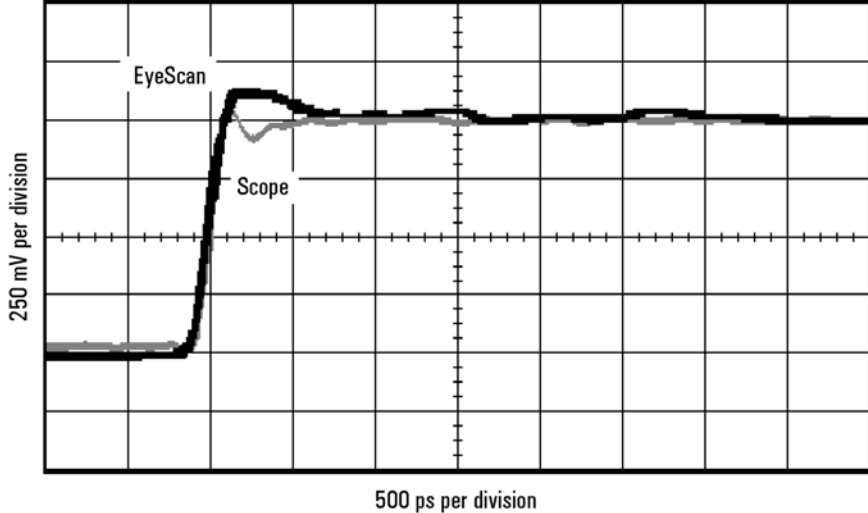

Figure 37 Logic analyzer's response to a 250 ps rise time

NOTE

These measurements are not the true step response of the probes. The true step response of a probe is the output of the probe while the input is a perfect step.

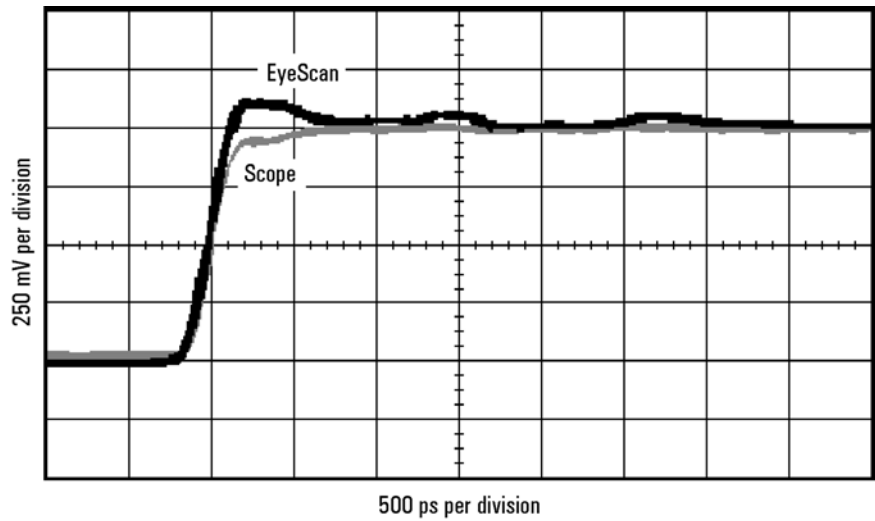

Figure 38 Logic analyzer's response to a 500 ps rise time

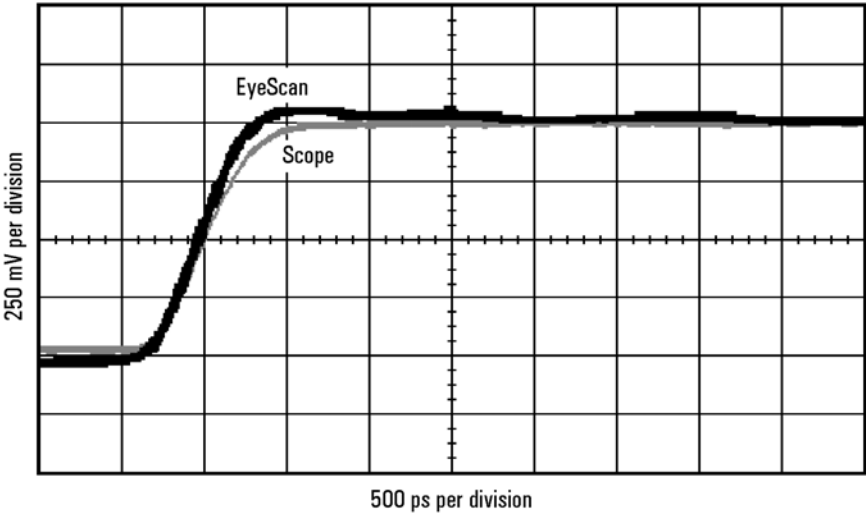

Figure 39 Logic analyzer's response to a 1 ns rise time

NOTE

These measurements are not the true step response of the probes. The true step response of a probe is the output of the probe while the input is a perfect step.

Eye Opening

The eye opening at the logic analyzer is the truest measure of an analyzer's ability to accurately capture data. Seeing the eye opening at the logic analyzer is possible with Eye Scan. Eye opening helps you know how much margin the logic analyzer has, where to sample and at what threshold. Any probe response that exhibits overshoot and ringing, probe non-flatness, noise and other issues all deteriorate the eye opening seen by the logic analyzer. The following eye diagrams were measured using Eye Scan probed mid-bus on a $50\ \Omega$ transmission line load terminated at the receiver. The data patterns were generated using a $2^{23}-1$ pseudo random bit sequence (PRBS). These measurements show the remaining eye opening at the logic analyzer while using the 5cm resistive signal lead and solder-down ground lead configuration.

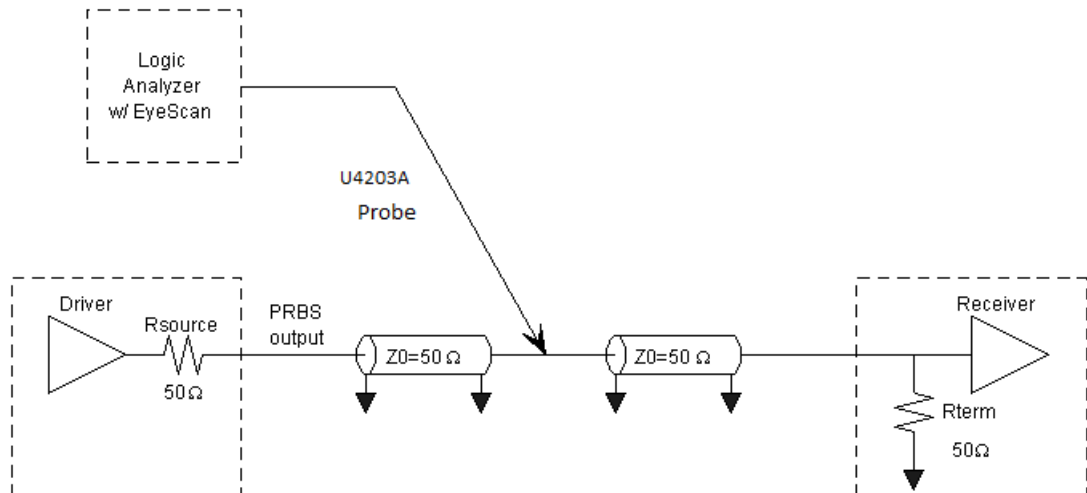

Figure 40 Eye opening measurement schematic

The logic analyzer Eye Scan measurement uses the same circuitry as the synchronous state mode analysis. Therefore, the eye openings measured are exact representations of what the logic analyzer sees and operates on in state mode. The following measurements demonstrate how the eye opening starts to collapse as the clock rate is increased. At 1500 Mb/s, the eye opening is noticeably deteriorating as jitter on the transitions increase and voltage margins decrease. The bandwidth limiting of the 5 cm resistive signal lead causes more roll-off on the transitions. As demonstrated by the last eye diagram, the 5 cm resistive signal lead and solder-down ground lead configuration still has a usable eye opening at 1250Mb/s and minimum signal swing.

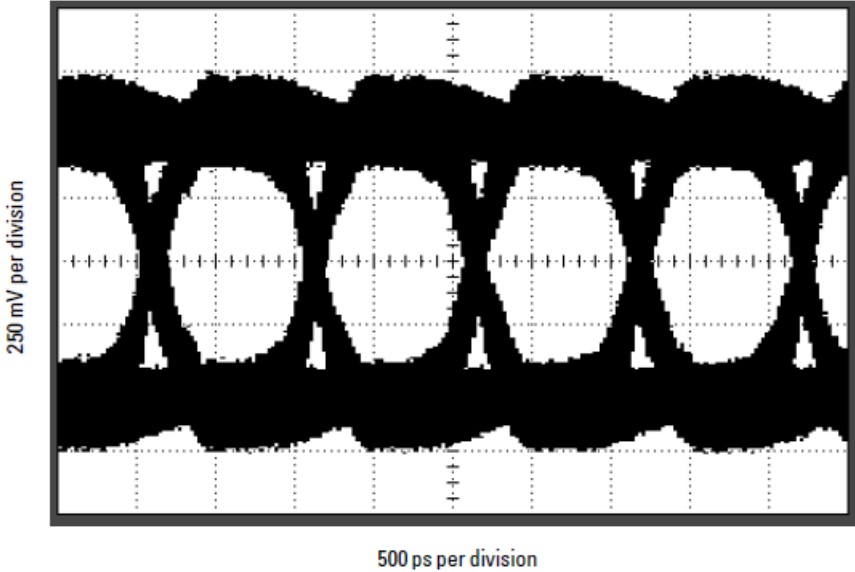

Figure 41 Logic analyzer eye opening for a PRBS signal of 1 V p-p, 100 Mb/s data rate

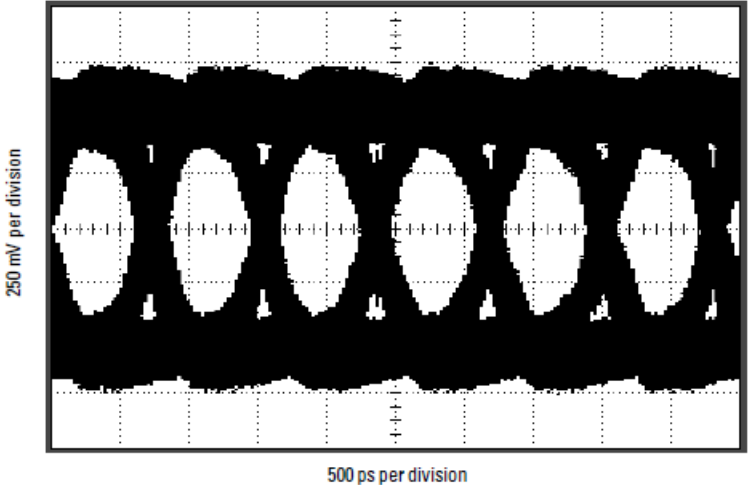

Figure 42 Logic analyzer eye opening for a PRBS signal of 1 V p-p, 1250 Mb/s data rate

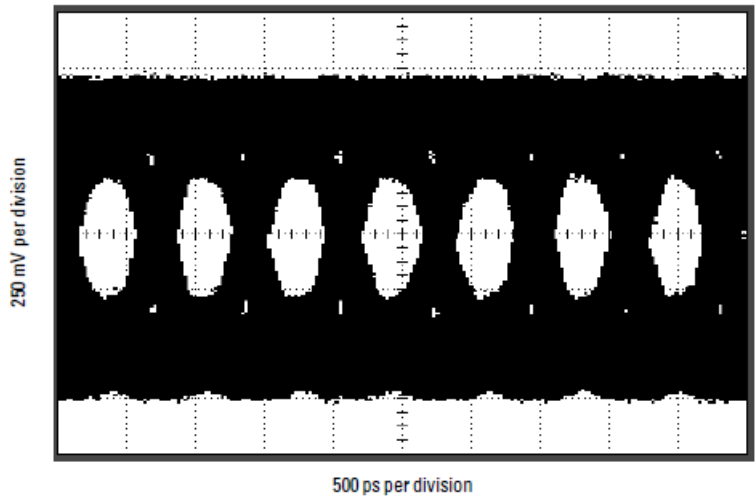

Figure 43 Logic analyzer eye opening for a PRBS signal of 1 V p-p, 1500 Mb/s data rate

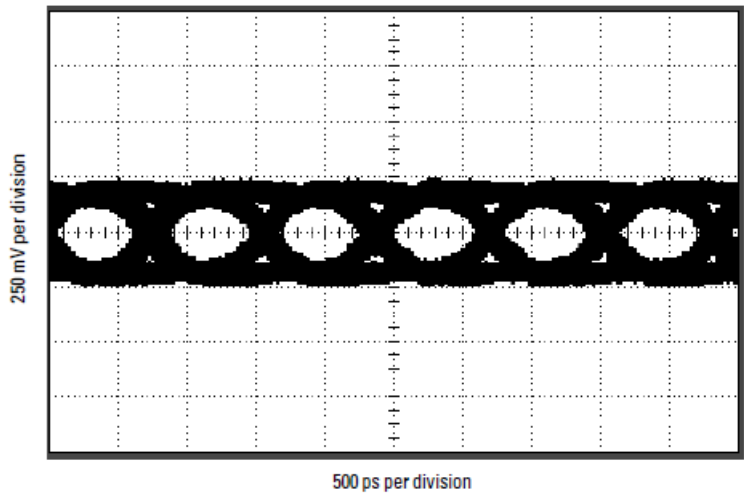

Figure 44 Logic analyzer eye opening for a PRBS signal of 250 mV p-p, 1250 Mb/s data rate

Flying Lead and Ground Extender

This configuration is recommended when you can provide 0.635 mm (0.025 in.) square or round pins on 2.54 mm (0.1 in.) centers as test points where you wish to connect the probe. Alternately, you may substitute soldered-down wires of similar length (up to 1 cm in length) and expect to achieve similar results.

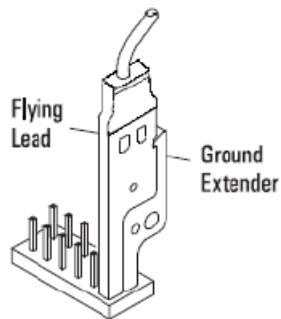

Figure 45 Pin probing configuration

All of the measurements for the flying lead and ground extender configuration were made with standard surface-mount pins on 0.1-inch centers soldered to the test fixture. The input impedance, TDT response, step response, and eye opening measurements all include the combined load of the probe configuration and the surface-mount pins on the target.

Input Impedance

The U4203A probes have an input impedance which varies with frequency, and depends on which accessories are being used. The following schematic shows the circuit model for the input impedance of the probe

when using the ground extender clip. This model is a simplified equivalent load of the measured input impedance seen by the target.

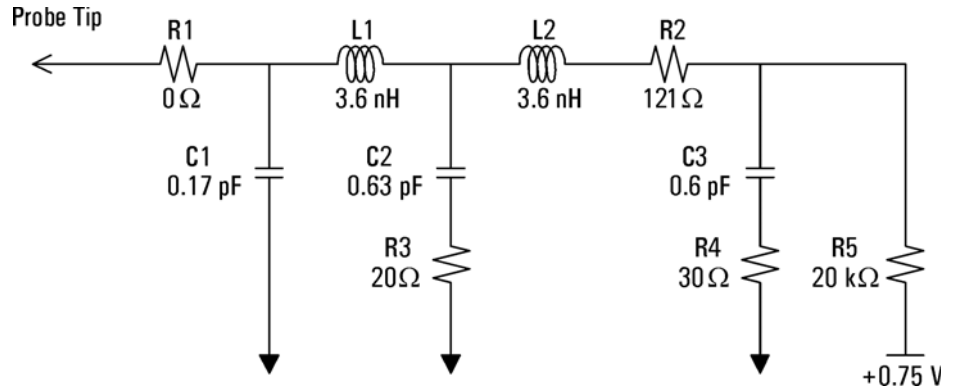

Figure 46 Equivalent load model

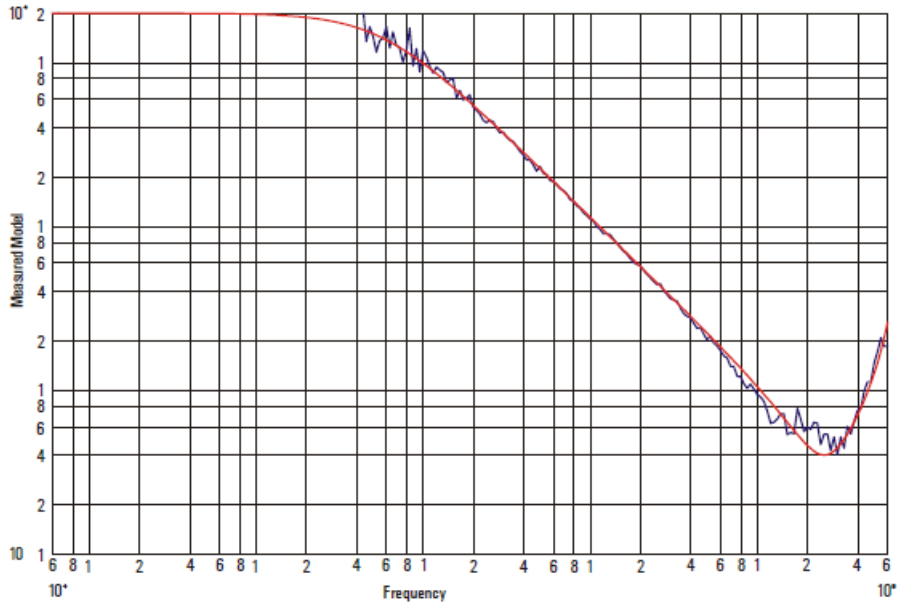

Figure 47 Measured versus modeled input impedance

Time Domain Transmission (TDT)

All probes have a loading effect on the circuit when they come in contact with the circuit. Time domain transmission (TDT) measurements are useful for understanding the probe loading effects as seen at the target receiver. The following TDT measurements were made mid-bus on a $50\ \Omega$ transmission line load terminated at the receiver. These measurements show how the flying lead and ground extender configuration affect the step seen by the receiver for various rise times.

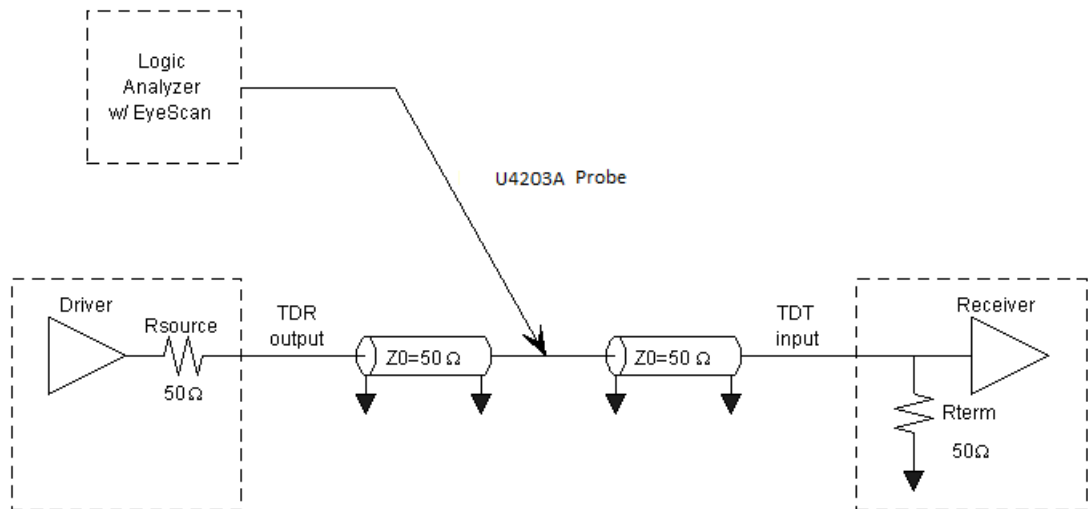

Figure 48 TDT measurement schematic

The recommended configurations are listed in order of loading on the target. As the following graphs demonstrate, the flying lead and ground extender configuration has the 3rd best loading of the four recommended configurations. However, because most of the capacitance of this configuration is undamped, the loading is more noticeable than the previous two configurations. The graphs show that the loading effects are negligible for targets with rise times ≥ 500 ps, probably still acceptable for targets with 250 ps rise times, and may be considered significant for 100 ps rise times. Ultimately, you must determine what is an acceptable amount of distortion of the target signal.

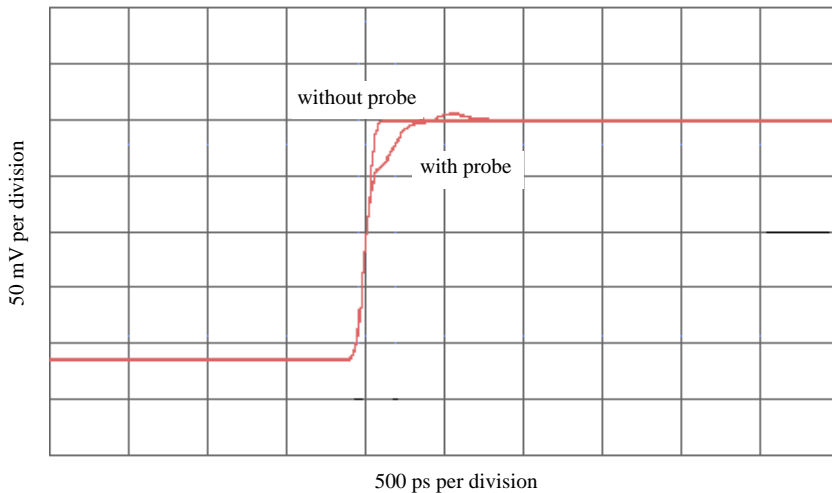

Figure 49 TDT measurement at receiver with and without probe load for 100 ps rise time

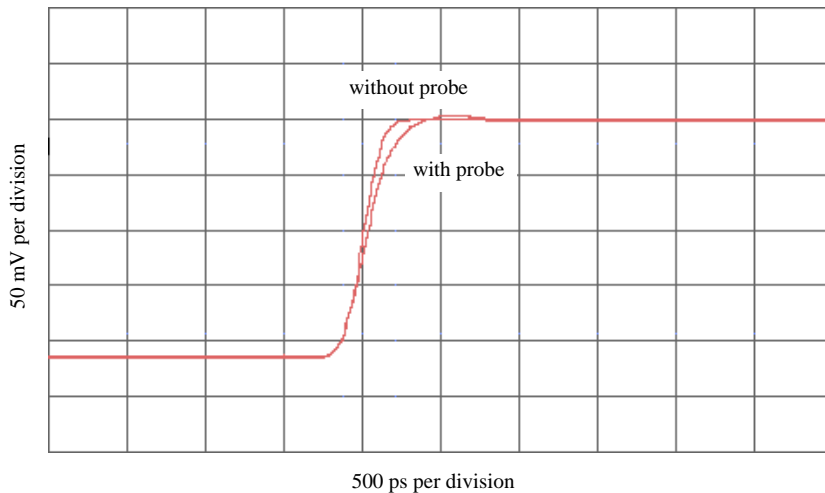

Figure 50 TDT measurement at receiver with and without probe load for 250 ps rise time

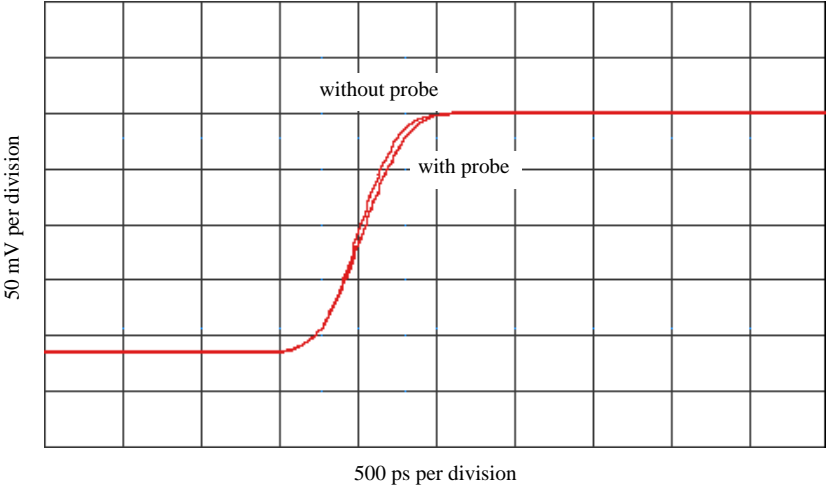

Figure 51 TDT measurement at receiver with and without probe load for 500 ps rise time

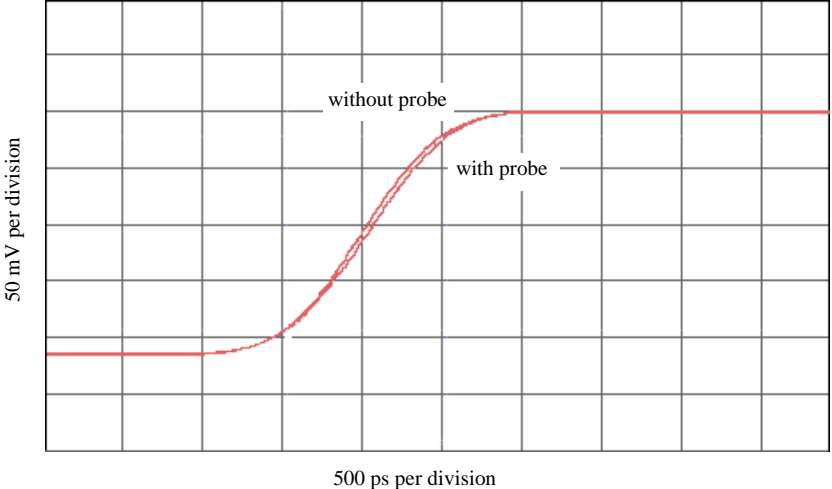

Figure 52 TDT measurement at receiver with and without probe load for 1 ns rise time

Step Input

Maintaining signal fidelity to the logic analyzer is critical if the analyzer is to accurately capture data. One measure of a system's signal fidelity is to compare V_{in} to V_{out} for various step inputs. For the following graphs, V_{in} is the signal at the logic analyzer probe tip measured by double probing with Keysight 54701A probe into Keysight 54750A oscilloscope (total 2.5 GHz BW). Eye Scan is used to measure V_{out} , the signal seen by the logic analyzer. The measurements were made on a mid-bus connection to a 50 Ω transmission line load_terminated at the receiver. These measurements show the logic analyzer's response while using the flying lead and ground extender configuration.

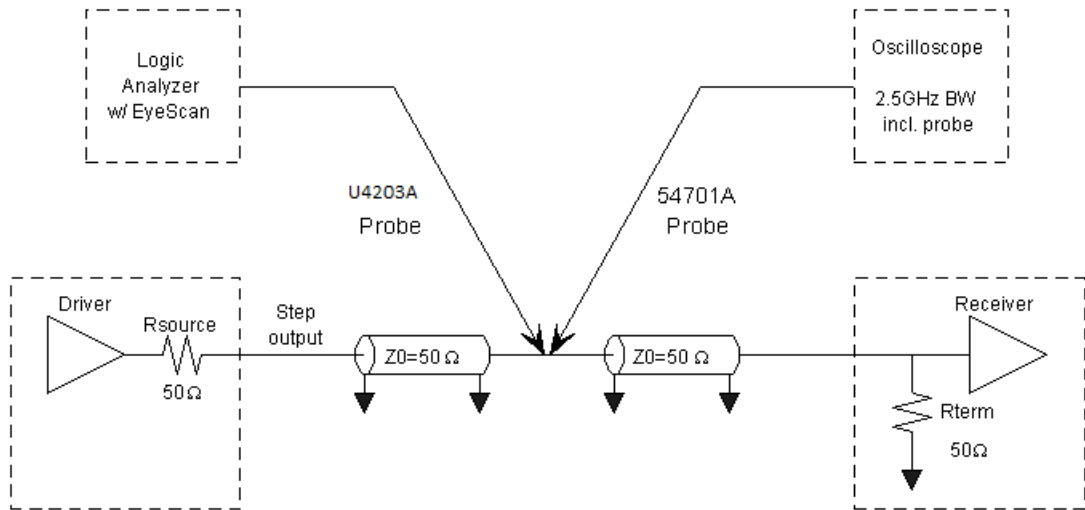

Figure 53 Step measurement schematic

The following graphs demonstrate the logic analyzer's probe response to different rise times. These graphs are included for you to gain insight into the expected performance of the different recommended accessory configurations.

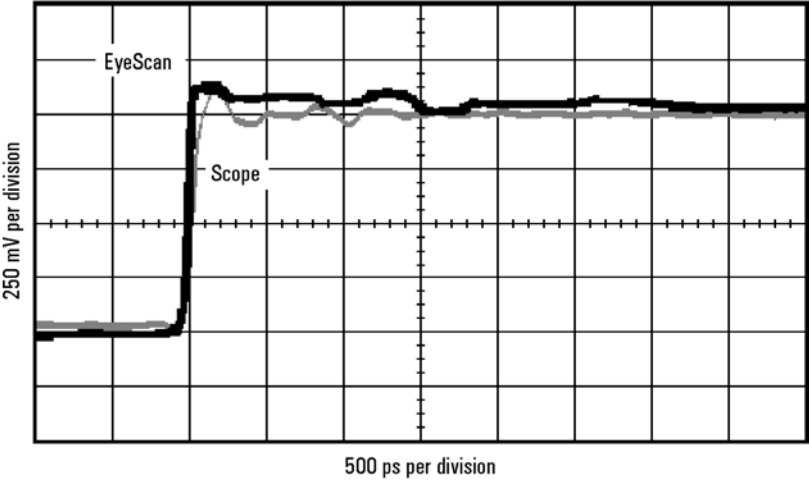

Figure 54 Logic analyzer's response to a 100 ps rise time

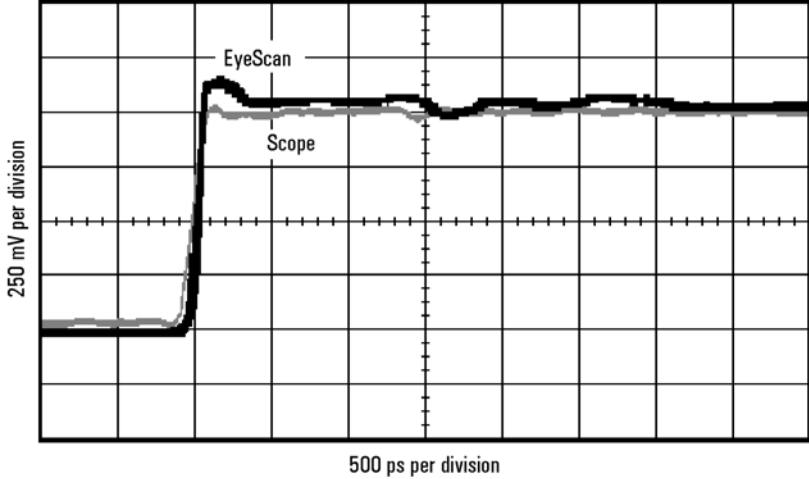

Figure 55 Logic analyzer's response to a 250 ps rise time

NOTE

These measurements are not the true step response of the probes. The true step response of a probe is the output of the probe while the input is a perfect step.

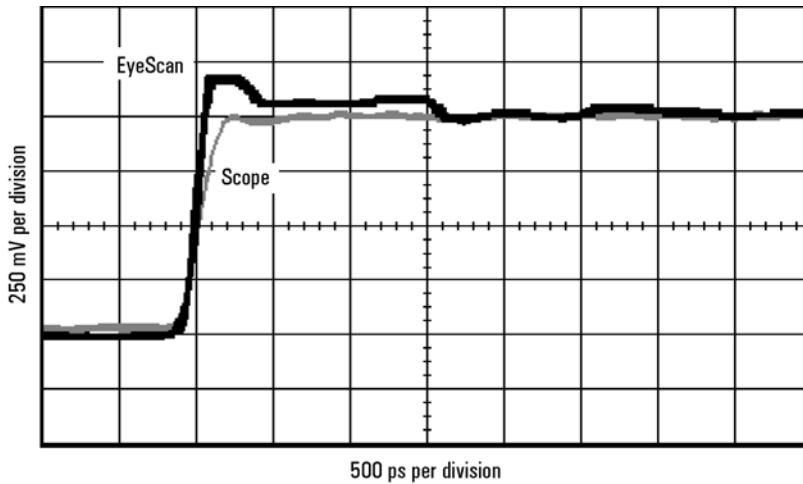

Figure 56 Logic analyzer's response to a 500 ps rise time

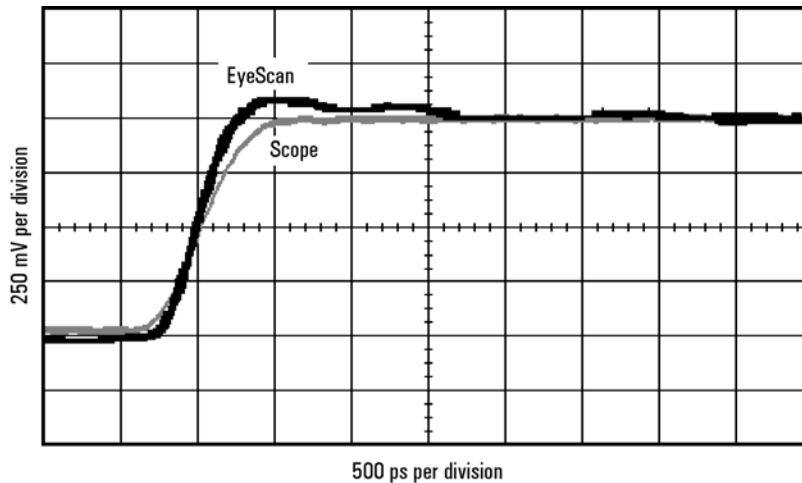

Figure 57 Logic analyzer's response to a 1 ns rise time

NOTE

These measurements are not the true step response of the probes. The true step response of a probe is the output of the probe while the input is a perfect step.

Eye Opening

The eye opening at the logic analyzer is the truest measure of an analyzer's ability to accurately capture data. Seeing the eye opening at the logic analyzer is possible with Eye Scan. Eye opening helps you know how much margin the logic analyzer has, where to sample and at what threshold. Any probe response that exhibits overshoot and ringing, probe non-flatness, noise and other issues all deteriorate the eye opening seen by the logic analyzer. The following eye diagrams were measured using Eye Scan probed mid-bus on a $50\ \Omega$ transmission line load terminated at the receiver. The data patterns were generated using a $2^{23}-1$ pseudo random bit sequence (PRBS). These measurements show the remaining eye opening at the logic analyzer while using the flying lead and ground extender configuration.

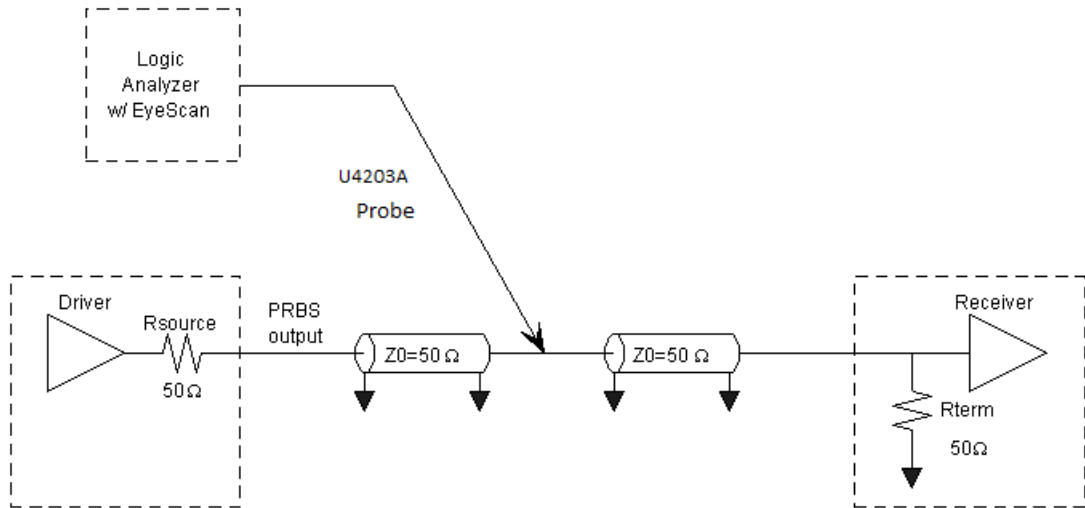

Figure 58 Eye opening measurement schematic

The logic analyzer Eye Scan measurement uses the same circuitry as the synchronous state mode analysis. Therefore, the eye openings measured are exact representations of what the logic analyzer sees and operates on in state mode. The following measurements demonstrate how the eye opening starts to collapse as the clock rate is increased. The peaking observed with this configuration on the preceding step-response graphs helps to preserve the eye opening out to 1.5 Gb/s. At 1500 Mb/s the eye opening is still as large as could be hoped for. As demonstrated by the last eye diagram, the flying lead and ground extender configuration still has no noticeable deterioration at 1500 Mb/s and minimum signal swing.

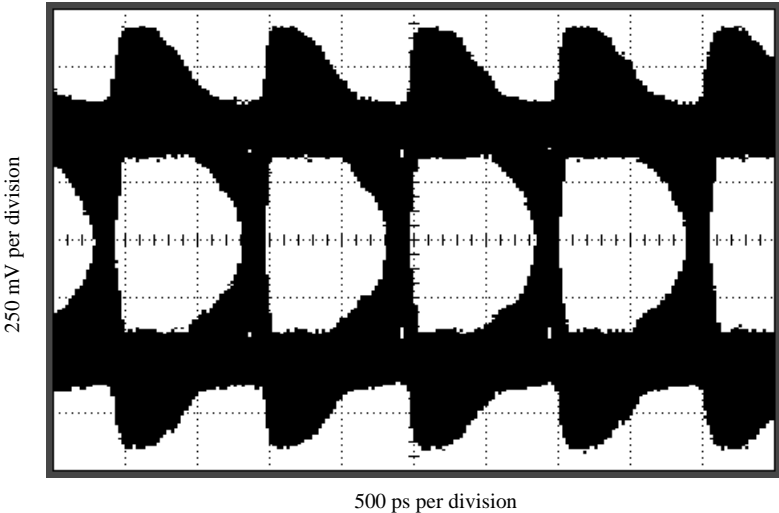

Figure 59 Logic analyzer eye opening for a PRBS signal of 1 V p-p, 1000 Mb/s data rate

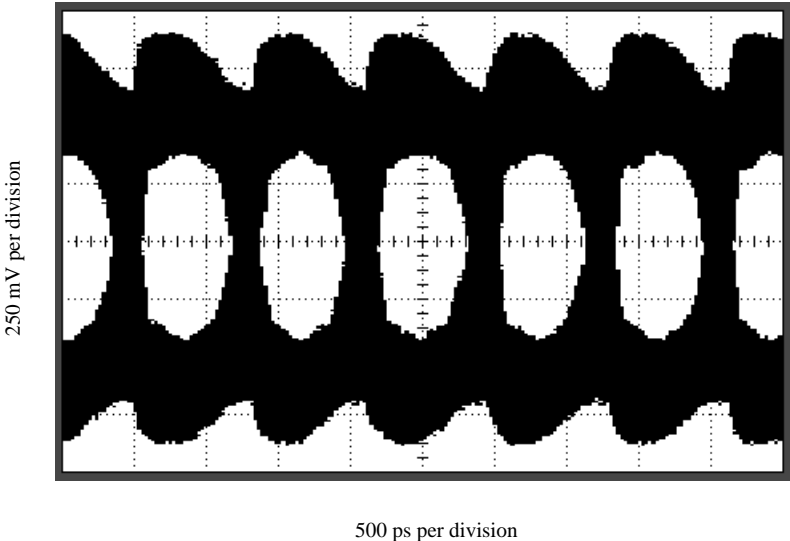

Figure 60 Logic analyzer eye opening for a PRBS signal of 1 V p-p, 1250 Mb/s data rate

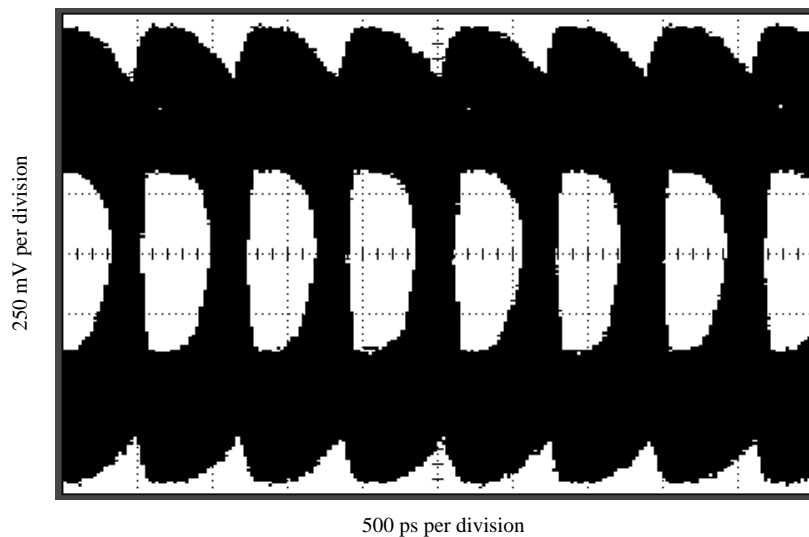

Figure 61 Logic analyzer eye opening for a PRBS signal of 1 V p-p, 1500 Mb/s data rate

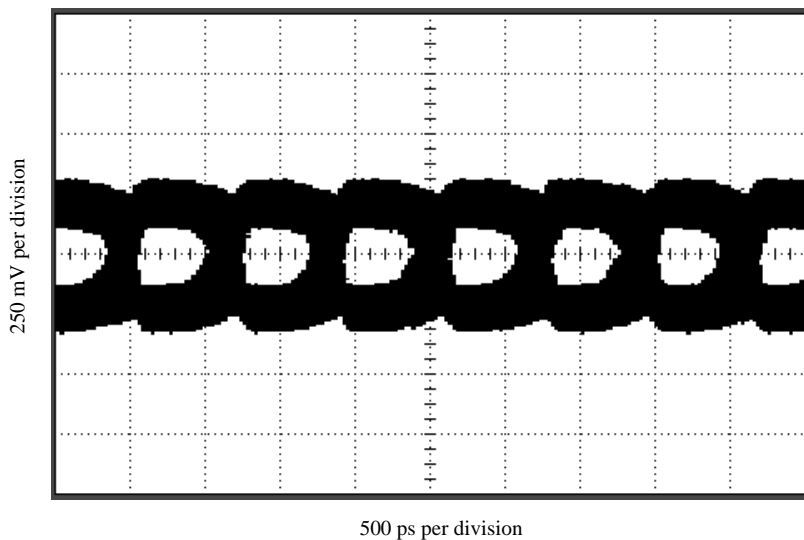

Figure 62 Logic analyzer eye opening for a PRBS signal of 250 mV p-p, 1500 Mb/s data rate

Grabber Clip and Right-angle Ground Lead

Using the grabber clip for the signal and the right-angle for the ground gives you the greatest flexibility for attaching the probe to component leads, however as you can see from the following information, the signal quality is compromised the most severely by this configuration.

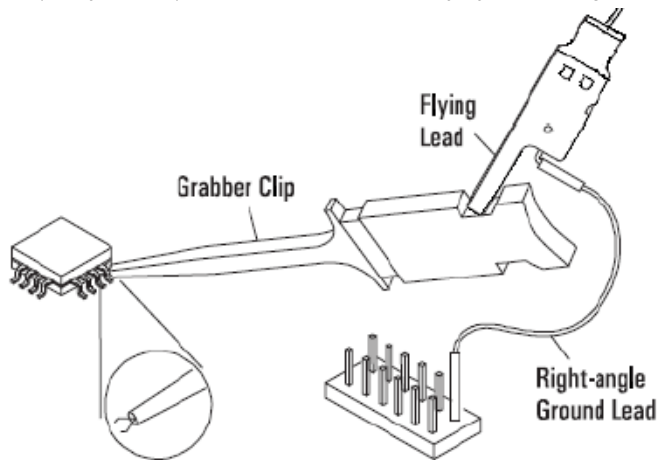

Figure 63 Grabber configuration

This configuration is provided as a convenient method of attaching to systems with slower rise times. The response of the probe is severely over-peaked. The load on the target is also the most severe of the 4 recommended configurations. As will be demonstrated in the following sets of measurements, the grabber clip and right angle ground lead configuration is only for systems with rise times slower than 1ns or effective clock rates less than 600Mb/s.

NOTE

It is critical to maintain good probing techniques on the clock signal. If the clock being probed has <1 ns rise times, use an alternative configuration for probing.

Input Impedance

The U4203A probes have an input impedance which varies with frequency, and depends on which accessories are being used. The following schematic shows the circuit model for the input impedance of the probe when using the SMD IC grabber and the right-angle ground lead. This

model is a simplified equivalent load of the measured input impedance seen by the target.

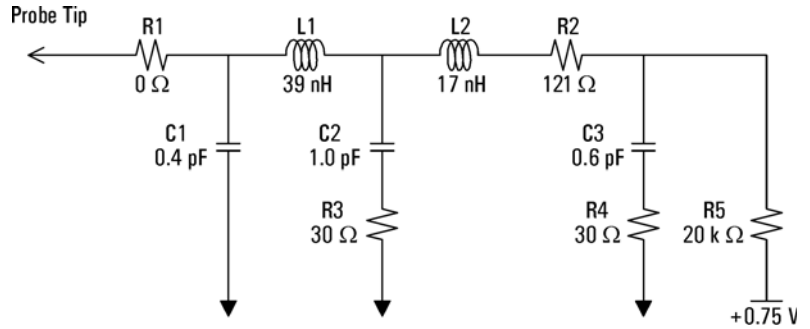

Figure 64 Equivalent load model

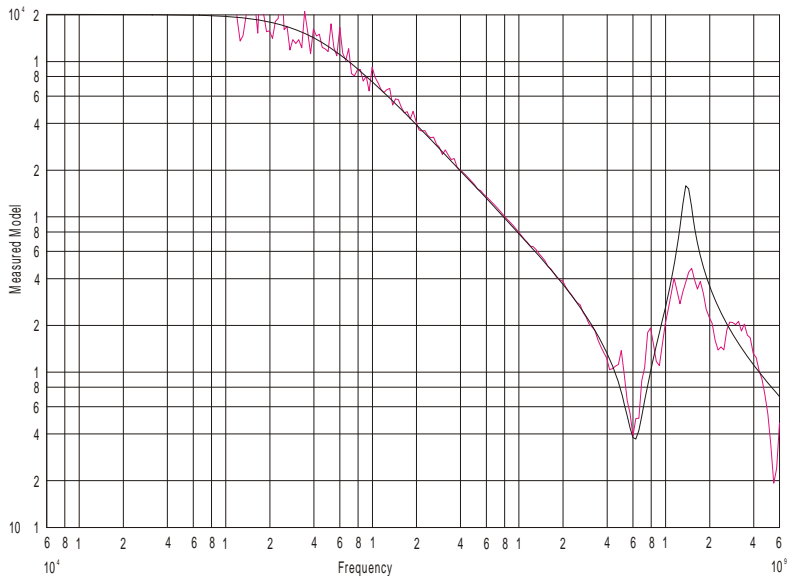

Figure 65 Measured versus modeled input impedance

Time Domain Transmission (TDT)

All probes have a loading effect on the circuit when they come in contact with the circuit. Time domain transmission (TDT) measurements are useful for understanding the probe loading effects as seen at the target receiver. The following TDT measurements were made mid-bus on a $50\ \Omega$ transmission line load terminated at the receiver. These measurements show how the grabber clip and right-angle ground lead configuration affect the step seen by the receiver for various rise times.

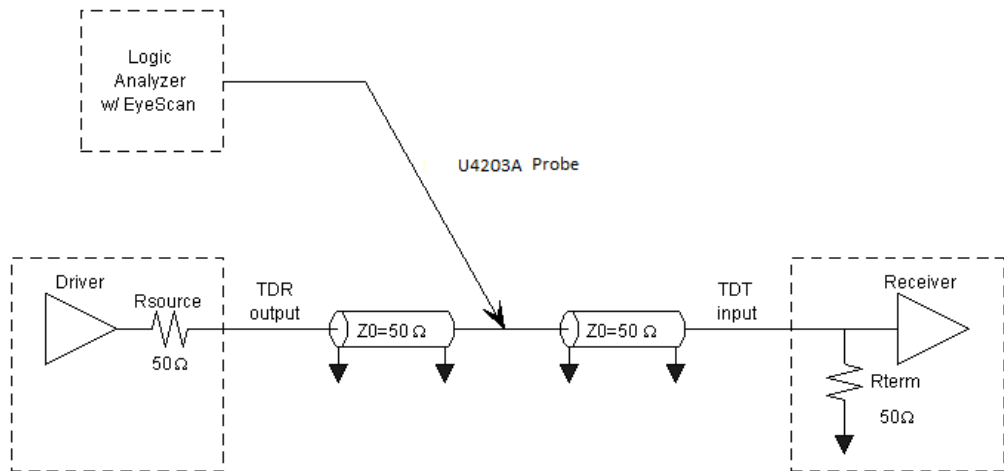

Figure 66 TDT measurement schematic

The recommended configurations are listed in order of loading on the target. As the following graphs demonstrate, the grabber clip and right angle ground lead configuration has the worst loading of the four recommended configurations. The grabber clip is a fairly long length of undamped wire, which presents a much more significant load on the target than the previous three configurations. The graphs show that the loading effects are noticeable even for targets with 1 ns rise times. Ultimately, you must determine what is an acceptable amount of distortion of the target signal.



Figure 67 TDT measurement at receiver with and without probe load for 100 ps rise time

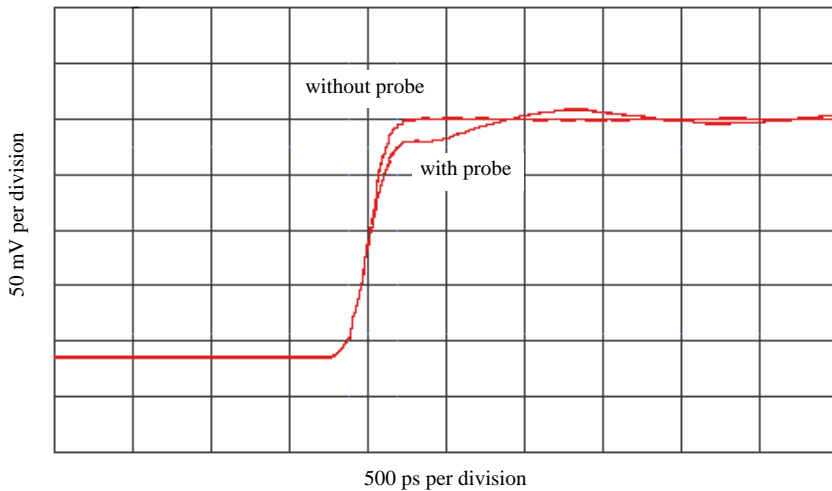

Figure 68 TDT measurement at receiver with and without probe load for 250 ps rise time

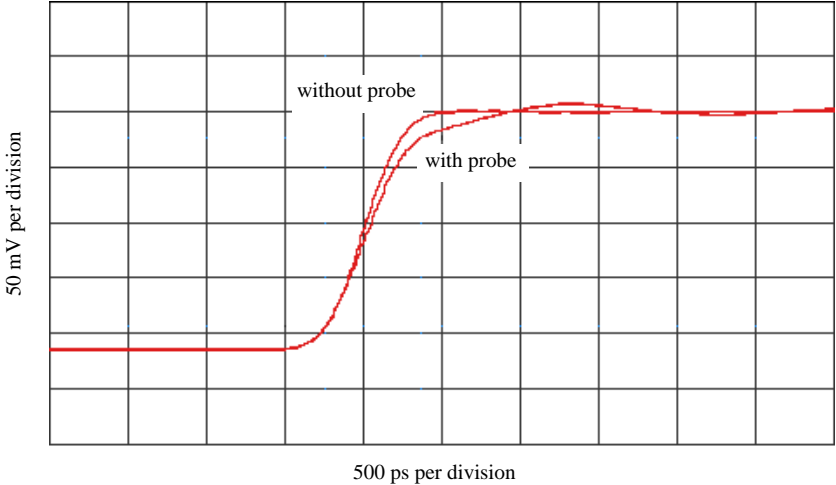

Figure 69 TDT measurement at receiver with and without probe load for 500 ps rise time

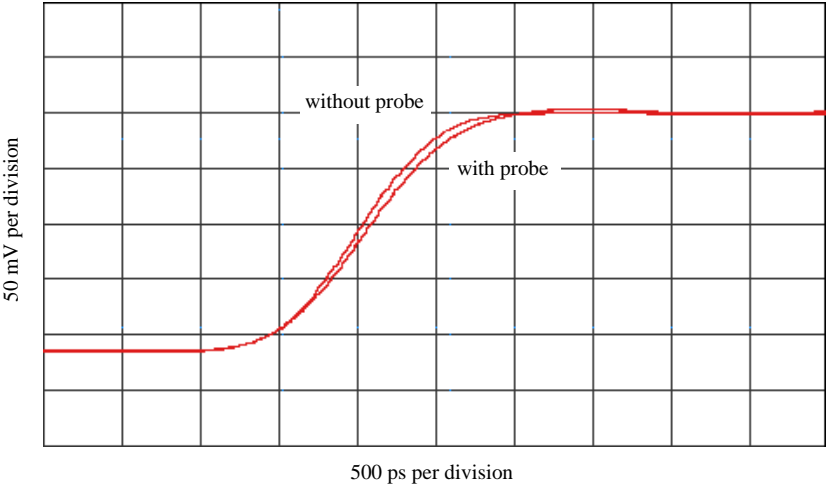

Figure 70 TDT measurement at receiver with and without probe load for 1 ns rise time

Step Input

Maintaining signal fidelity to the logic analyzer is critical if the analyzer is to accurately capture data. One measure of a system's signal fidelity is to compare V_{in} to V_{out} for various step inputs. For the following graphs, V_{in} is the signal at the logic analyzer tip measured by double probing with Keysight 54701A probe into Keysight 54750A oscilloscope (total 2.5 GHz BW). Eye Scan is used to measure V_{out} , the signal seen by the logic analyzer. The measurements were made on a mid-bus connection to a 50 Ω transmission line load terminated at the receiver. These measurements show the logic analyzer's response while using the grabber clip and right-angle ground lead configuration.

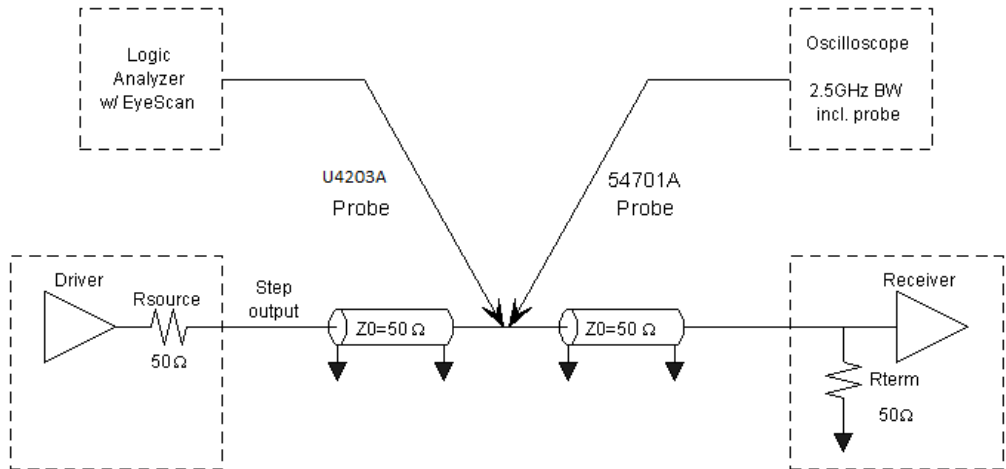

Figure 71 Step measurement schematic

The following graphs demonstrate the logic analyzer's probe response to different rise times. These graphs are included for you to gain insight into the expected performance of the different recommended accessory configurations, particularly for the grabber clip and right-angle ground lead configuration. As the following graphs will demonstrate, the use of the undamped grabber clip results in excessive overshoot and ringing at the logic analyzer for targets with < 1 ns rise times.

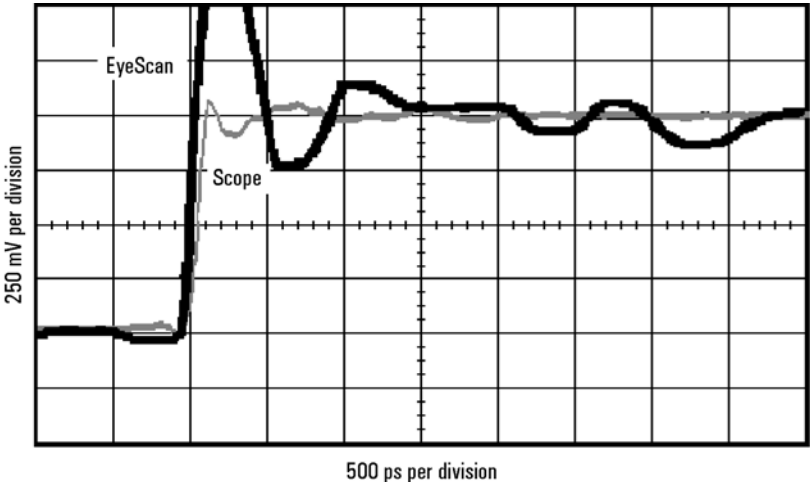

Figure 72 Logic analyzer's response to a 100 ps rise time

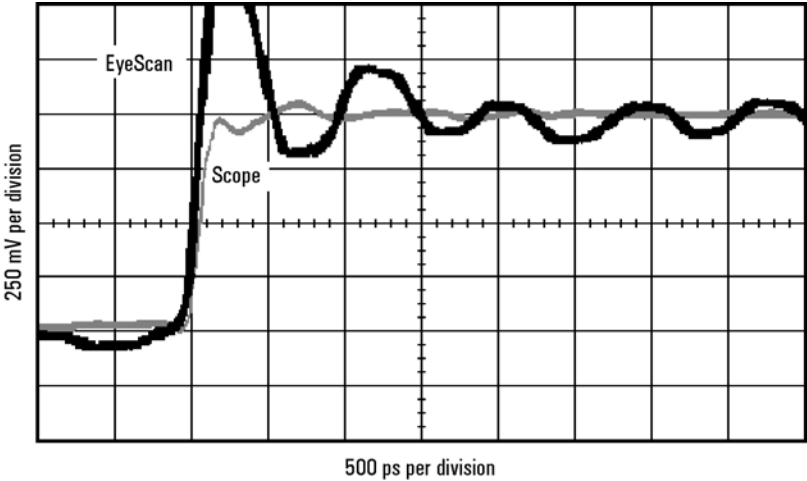

Figure 73 Logic analyzer's response to a 250 ps rise time

NOTE

These measurements are not the true step response of the probes. The true step response of a probe is the output of the probe while the input is a perfect step.

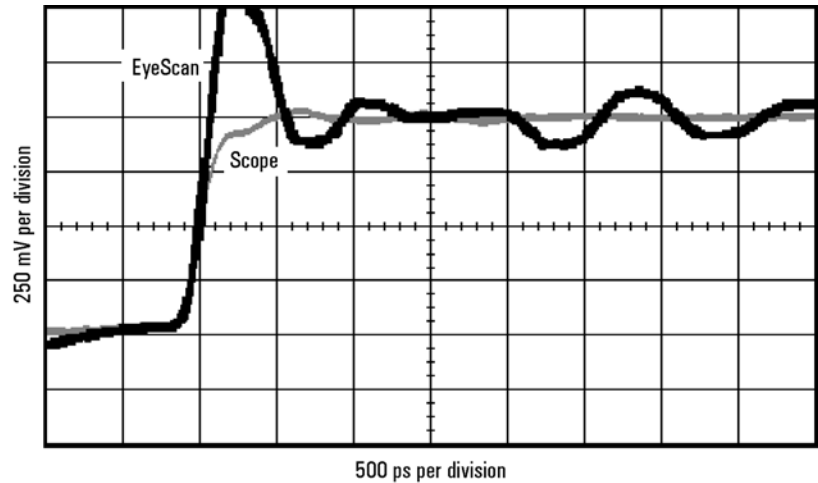

Figure 74 Logic analyzer's response to a 500 ps rise time

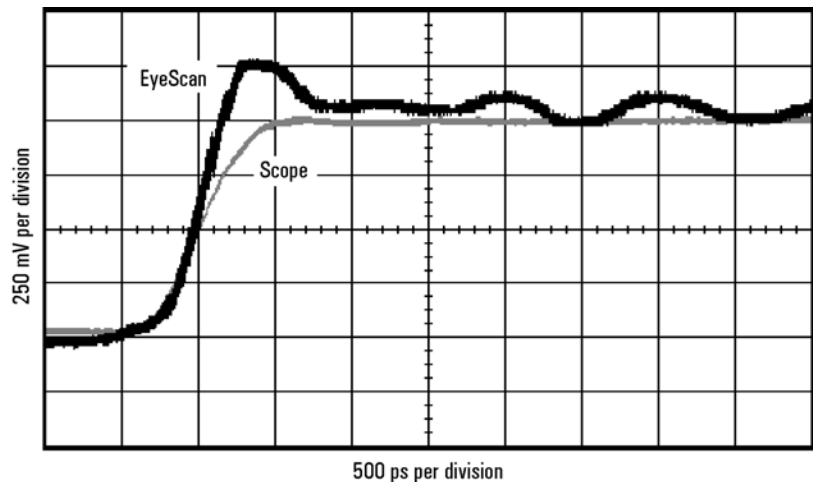

Figure 75 Logic analyzer's response to a 1 ns rise time

NOTE

These measurements are not the true step response of the probes. The true step response of a probe is the output of the probe while the input is a perfect step.

Eye Opening

The eye opening at the logic analyzer is the truest measure of an analyzer's ability to accurately capture data. Seeing the eye opening at the logic analyzer is possible with Eye Scan. Eye opening helps you know how much margin the logic analyzer has, where to sample and at what threshold. Any probe response that exhibits overshoot and ringing, probe non-flatness, noise and other issues all deteriorate the eye opening seen by the logic analyzer. The following eye diagrams were measured using Eye Scan probed mid-bus on a $50\ \Omega$ transmission line load terminated at the receiver. The data patterns were generated using a $2^{23}-1$ pseudo random bit sequence (PRBS). These measurements show the remaining eye opening at the logic analyzer while using the grabber clip and right-angle ground lead configuration.

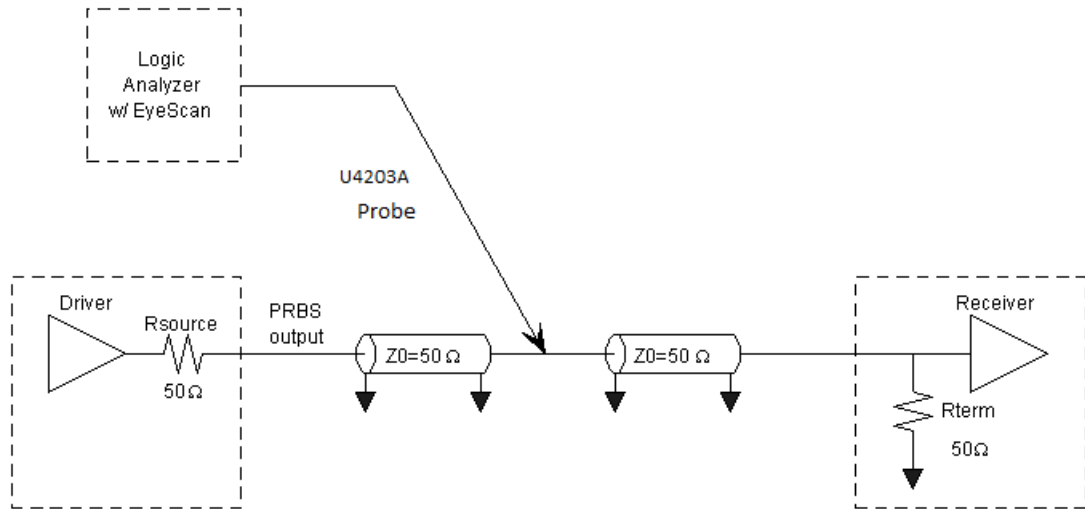

Figure 76 Eye opening measurement schematic

The logic analyzer Eye Scan measurement uses the same circuitry as the synchronous state mode analysis. Therefore, the eye openings measured are exact representations of what the logic analyzer sees and operates on in state mode. The following measurements demonstrate how the eye opening starts to collapse as the clock rate is increased. The severe overshoot and ringing observed with this configuration on the preceding step-response graphs deteriorates the eye opening for faster rise times. At 500 ps rise times the eye opening shows excessive ring-back and collapsing of the eye. Therefore, it is recommended that this configuration not be used for rise times faster than 1 ns or clock rates in excess of 600 Mb/s. The analyzer may still function at faster speeds, but will not meet state speed and setup/hold specifications.

NOTE

it is critical to maintain good probing techniques on the clock signal. if the clock being probed has < 1 ns rise times, use an alternative configuration for probing.

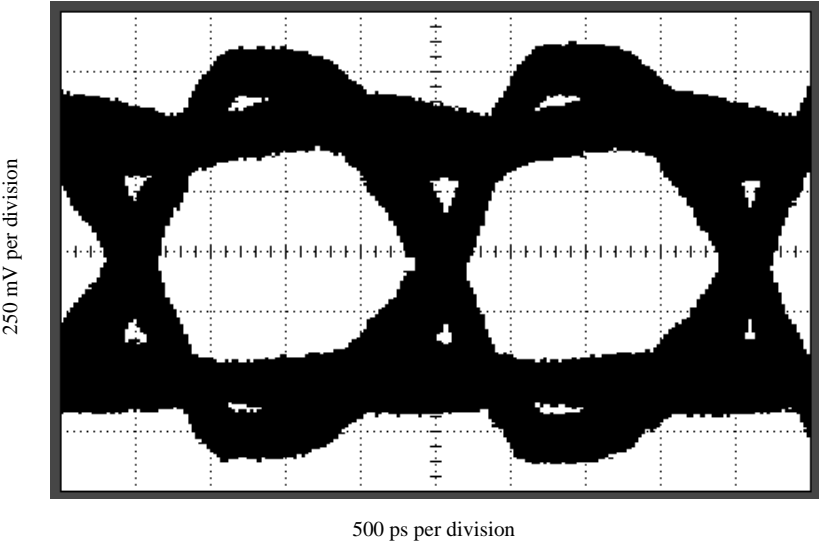

Figure 77 Logic analyzer eye opening for a PRBS signal of 1 V p-p, 500 Mb/s data rate, 1 ns rise time

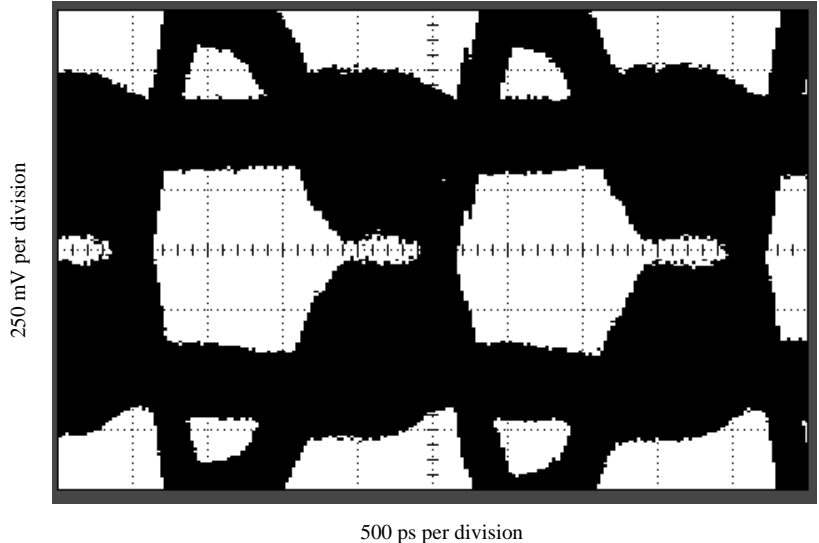

Figure 78 Logic analyzer eye opening for a PRBS signal of 1 V p-p, 500 Mb/s data rate, 500 ps rise time

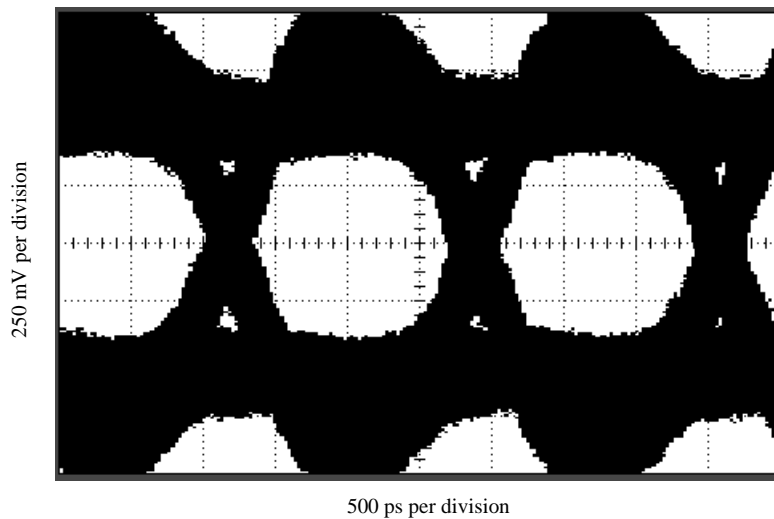

Figure 79 Logic analyzer eye opening for a PRBS signal of 1 V p-p, 600 Mb/s data rate, 1 ns rise time

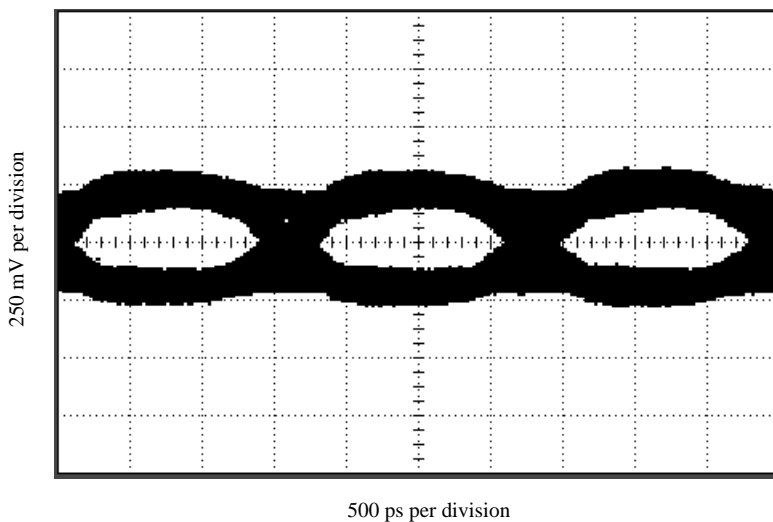

Figure 80 Logic analyzer eye opening for a PRBS signal of 250 mV, 600 Mb/s data rate, 1 ns rise time

Connecting to Coaxial Connectors

You can use the Keysight E9638A to adapt the probe tip to a BNC connector. The adapter and the BNC connector itself will add significant capacitance to the probe load. You can generally assume (though not always) that a BNC connector is intended to form a part of a transmission line terminated in $50\ \Omega$ (the characteristic impedance of BNC connectors is $50\ \Omega$). So, the best solution for maintaining signal integrity is to terminate the line in $50\ \Omega$ after the BNC connector and as close as possible to the probe tip. That technique minimizes the length of the unterminated stub past the termination. The following picture shows the recommended configuration to achieve this.

NOTE

This configuration has not been characterized for target loading or logic analyzer performance. Therefore no recommendations are being made or implied as to the expected performance of this configuration.

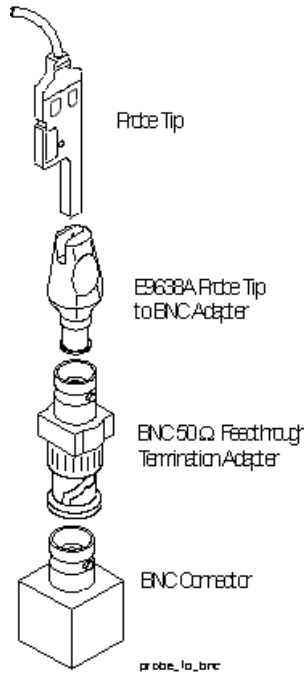

Figure 81 BNC connector

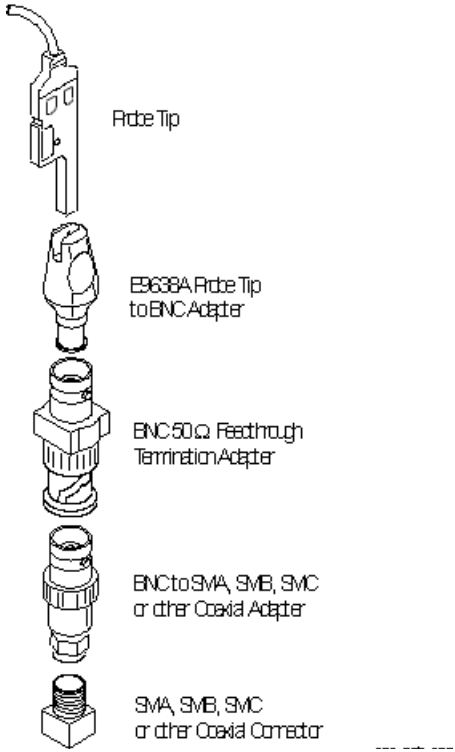

Figure 82 SMA, SMB, SMC, or other coaxial connectors

Combining Grounds

It is essential to ground every tip that is in use. For best performance at high speeds, every tip should be grounded individually to ground in the system under test. For convenience in connecting grounds, you can use the ground connector, Keysight part number 16515-27601, to combine four probe tip grounds to connect to one ground point in the system under test.

Using the 16515-27601 to combine grounds will have some negative impact on performance due to coupling caused by common ground return currents. The exact impact depends on the signals being tested and the configuration of the test, so it is impossible to predict accurately. In general, the faster the rise time of the signals under test, the greater the risk of coupling.

In no case should more than four tip grounds be combined through one 16515-27601 to connect to ground in the system under test.

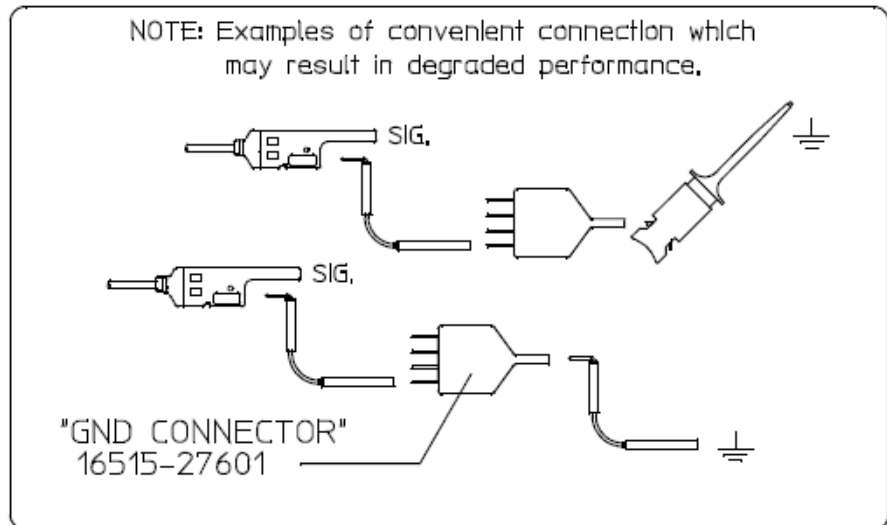

Safety Information

The following general safety precautions must be observed during all phases of operation of this instrument. Failure to comply with these precautions or with specific warnings or operating instructions in the product manuals violates safety standards of design, manufacture, and intended use of the instrument. Keysight Technologies assumes no liability for the customer's failure to comply with these requirements. Product manuals are provided with your instrument on CD-ROM and/or in printed form. Printed manuals are an option for many products. Manuals may also be available on the Web. Go to www.keysight.com and type in your product number in the Search field at the top of the page.

General	Do not use this product in any manner not specified by the manufacturer. The protective features of this product may be impaired if it is used in a manner not specified in the operation instructions.
Before Applying Power	Verify that all safety precautions are taken. Make all connections to the unit before applying power. Note the instrument's external markings described in "Safety Symbols".
Ground the Instrument	If your product is provided with a grounding type power plug, the instrument chassis and cover must be connected to an electrical ground to minimize shock hazard. The ground pin must be firmly connected to an electrical ground (safety ground) terminal at the power outlet. Any interruption of the protective (grounding) conductor or disconnection of the protective earth terminal will cause a potential shock hazard that could result in personal injury.
Fuses	See the user's guide or operator's manual for information about line-fuse replacement. Some instruments contain an internal fuse, which is not user accessible.
Do Not Operate in an Explosive Atmosphere	Do not operate the instrument in the presence of flammable gases or fumes.
Do Not Remove the Instrument Cover	Only qualified, service-trained personnel who are aware of the hazards involved should remove instrument covers. Always disconnect the power cable and any external circuits before removing the instrument cover.
Cleaning	Clean the outside of the instrument with a soft, lint-free, slightly dampened cloth. Do not use detergent or chemical solvents.
Do Not Modify the Instrument	Do not install substitute parts or perform any unauthorized modification to the product. Return the product to Keysight Sales and Service Office for service and repair to ensure that safety features are maintained.
In Case of Damage	Instruments that appear damaged or defective should be made inoperative and secured against unintended operation until they can be repaired by qualified service personnel.









CAUTION











A CAUTION notice denotes a hazard. It calls attention to an operating procedure, practice, or the like that, if not correctly performed or adhered to, could result in damage to the product or loss of important data. Do not proceed beyond a CAUTION notice until the indicated conditions are fully understood and met.

WARNING

A WARNING notice denotes a hazard. It calls attention to an operating procedure, practice, or the like that, if not correctly performed or adhered to, could result in personal injury or death. Do not proceed beyond a WARNING notice until the indicated conditions are fully understood and met.

Safety Symbols

Symbols	Description
	Direct current
	Alternating current
	Both direct and alternating current
	Three phase alternating current
	Earth ground terminal
	Protective earth ground terminal
	Frame or chassis ground terminal
	Terminal is at earth potential
	Equipotentiality

Symbols	Description
N	Neutral conductor on permanently installed equipment
L	Line conductor on permanently installed equipment
	On (mains supply)
	Off (mains supply)
	Stand by (mains supply). The instrument is not completely disconnected from the mains supply when the power switch is in the standby position
	In position of a bi-stable push switch
	Out position of a bi-stable push switch
	Equipment protected throughout by DOUBLE INSULATION or REINFORCED INSULATION
	Caution, refer to accompanying documentation
	Caution, risk of electric shock
	Do not apply around or remove from HAZARDOUS LIVE conductors
	Application around and removal from HAZARDOUS LIVE conductors is permitted
	Caution, hot surface
	Ionizing radiation
CAT I	IEC Measurement Category I

Symbols	Description
CAT II	Measurement Category II
CAT III	Measurement Category III
CAT IV	Measurement Category IV

Informations relatives à la sécurité

Les consignes de sécurité générales présentées dans cette section doivent être appliquées au cours des différentes phases d'utilisation de cet appareil. Le non-respect de ces précautions ou des avertissements et consignes d'utilisation spécifiques mentionnés dans les manuels des produits constitue une violation des normes de sécurité relatives à la conception, à la fabrication et à l'usage normal de l'instrument. Keysight Technologies ne saurait être tenu responsable du non-respect de ces consignes. Les manuels des produits sont fournis avec votre instrument sur CD-ROM et/ou en version papier. Les versions papier des manuels sont en option pour de nombreux produits. Certains manuels sont également disponibles en ligne. Pour y accéder, allez sur le site www.keysight.com et saisissez la référence de votre produit dans le champ Rechercher qui se trouve en haut de la page.

Généralités	Utilisez ce produit uniquement dans le cadre prévu par le fabricant. Si vous ne respectez pas les instructions d'utilisation, les fonctions de sécurité du produit risquent d'être inhibées.
Avant la mise sous tension	Vérifiez que vous avez bien respecté toutes les consignes de sécurité. Faites tous les branchements au niveau de l'appareil avant de mettre ce dernier sous tension. Tenez compte des marquages externes à l'instrument décrits à la section «Symboles de sécurité».
Mise à la terre de l'instrument	Si une prise de mise à la terre est fournie avec le produit, le châssis et le capot de l'instrument doivent être reliés à la terre afin de limiter les risques d'électrocution. Le contact à la terre doit être solidement connecté à une borne de terre (de sécurité) au niveau de la prise de courant. Toute interruption du conducteur de protection (mise à la terre) ou tout débranchement de la borne de terre de protection donne lieu à un risque d'électrocution pouvant entraîner des blessures graves.
Fusibles	Pour obtenir des instructions sur le changement des fusibles de ligne, consultez le guide de l'utilisateur ou le manuel d'instructions. Certains instruments comportent un fusible interne inaccessible à l'utilisateur.
Ne pas utiliser en atmosphère explosive	N'utilisez pas l'instrument en présence de gaz ou de vapeurs inflammables.
Ne pas démonter le capot de l'instrument	Seules des personnes qualifiées, formées à la maintenance et conscientes des risques d'électrocution encourus sont autorisées à démonter les capots de l'instrument. Débranchez toujours le cordon d'alimentation secteur et tous les circuits externes avant de démonter le capot de l'instrument.
Nettoyage	Nettoyez la partie externe de l'instrument à l'aide d'un chiffon doux et non pelucheux, légèrement humidifié. N'utilisez pas de détergents ou de solvants chimiques.
Ne pas modifier l'instrument	N'installez pas de composants de remplacement et n'apportez aucune modification non autorisée à l'appareil. Pour toute opération de maintenance ou de réparation, renvoyez l'appareil à un bureau de vente et de service après-vente keysight, afin d'être certain que les fonctions de sécurité seront maintenues.
En cas de dommages	Les instruments endommagés ou défectueux doivent être désactivés et protégés contre toute utilisation involontaire jusqu'à ce qu'ils aient été réparés par une personne qualifiée.









ATTENTION









La mention ATTENTION indique un risque. Si la manoeuvre ou le procédé correspondant n'est pas exécuté correctement, il peut y avoir un risque de dommages à l'appareil ou de perte de données importantes. En présence de la mention ATTENTION, il convient de s'interrompre tant que les conditions indiquées n'ont pas été parfaitement comprises et respectées.

AVERTISSEMENT

La mention AVERTISSEMENT signale un danger pour la sécurité de l'opérateur. Si la manoeuvre ou le procédé correspondant n'est pas exécuté correctement, il peut y avoir un risque pour la santé des personnes. En présence d'une mention AVERTISSEMENT, il convient de s'interrompre tant que les conditions indiquées n'ont pas été parfaitement comprises et respectées.

Symboles de sécurité:

Symboles	Description
	Courant continu.
	Courant alternatif.
	Courant continu et alternatif.
	Courant alternative triphasé.
	Borne de terre (masse).
	Borne de terre de protection.
	Borne de terre reliée au cadre ou au châssis.
	Borne au potentiel de la terre.
	Equipotentialité

Symboles	Description
N	Conducteur neutre sur un équipement installé à demeure
L	Conducteur de phase sur un équipement installé à demeure.
	Alimentation en marche.
	Alimentation à l'arrêt.
	Alimentation en mode veille. Lorsque l'interrupteur est en mode veille, l'unité n'est pas complètement déconnectée de l'alimentation secteur.
	Position Marche d'un interrupteur par bouton poussoir bi-stable.
	Position Arrêt d'un interrupteur par bouton poussoir bi-stable.
	Appareil entièrement protégé par DOUBLE ISOLATION ou ISOLATION RENFORCÉE
	Attention. Consultez la documentation fournie.
	Attention, danger d'électrocution.
	Ne pas appliquer ou enlever sur des conducteurs SOUS TENSION DANGEREUSE
	Application ou retrait autorisés sur les conducteurs SOUS TENSION DANGEREUSE
	Attention, surface chaude
	Rayonnement ionisant
CAT I	Appareil de mesure de catégorie I selon la norme CEI applicable

Symboles	Description
CAT II	Appareil de mesure de catégorie II selon la norme CEI applicable
CAT III	Appareil de mesure de catégorie III selon la norme CEI applicable
CAT IV	Appareil de mesure de catégorie IV selon la norme CEI applicable

Index

Numerics

- 130 ohm, 20
- 130 ohm resistive signal pin & solder-down ground lead, 20
- 5 cm resistive signal pin & solder-down ground lead, 35

A

- accessories, 9
- accuracy, 11
- additional, 9

B

- Berg strip, 49, 61
- Berg strip and IC, 61

C

- case contents, 7
- characteristics, 11, 12
- clock, 11
- clock input, 14
- coaxial connectors, 75
- configuration, 20, 35, 49, 61
- configurations, 18
- connecting to logic analyzer, 14

D

- damage, 7, 35
- differential, 14
- differential threshold, 14
- dimensions, 12

E

- environmental characteristics, 12
- extender, 49
- eye opening, 30, 46, 57, 69

F

- flying lead, 49
- flying lead and grabber clip, 61
- flying lead and ground extender, 49
- flying lead and signal pin, 20

G

- general characteristics, 12
- grabber clip, 61
- grabber clip and right-angle ground lead, 61
- ground, 20, 35, 49, 61

H

- hand-held probing, 20

I

- IC and pins, 61
- IC and surface mount, 61
- IC and test point, 35
- IC probing, 35
- input impedance, 20, 36, 49, 61
- inspecting probe, 7
- inspection, 7

L

- lead, 20

- lead, 5 cm, 35

O

- of probe, 11, 12
- operating environment, 12

P

- pin, 20
- pin probing, 49
- pins, 49
- probe, 7, 11, 12, 14
- probing, 20, 35, 49, 61, 75

R

- range, 11
- repair or replacement, 7
- resistive signal, 20, 35
- right angle, 61

S

- setting up the probe & logic analyzer, 14
- setup, 14
- SMA, 75
- SMB, 75
- SMC connectors, 75
- solder down, 20, 35
- solder-down ground, 20, 35
- specifications, 11
- state data rate, 11
- step input, 26, 42, 54, 66
- suggested configurations, 18
- supplied, 9
- surface-mount components, 35
- surface-mount probing, 35

Index

T

TDT, [22](#), [39](#), [51](#), [63](#)
test point, [20](#), [35](#)
test points, [20](#)
threshold, [11](#), [14](#), [16](#)
to the probe, [7](#)
to the resistor, [35](#)

U

user defined, [16](#)
user defined threshold, [16](#)

W

weight, [12](#)