



**Alltest Instruments, Inc.**

500 Central Ave.  
Farmingdale, NJ 07727

P: (732) 919-3339  
F: (732) 919-3332

**alltest.net**  
sales@alltest.net

## **The test & measurement equipment you need at the price you want.**

Alltest carries the world's largest selection of used/refurbished benchtop test & measurement equipment at 50% the price of new.

Our equipment is guaranteed working, warrantied, and available with certified calibration from our in-house staff of technicians and engineers.

- **10+ full time technicians with over 150 years of specialization**
- **90 day warranty & 5 day right of return on all equipment**
- **1-3 year warranties for new and premium-refurbished equipment**
- **Every unit tested to OEM specifications**
- **Satisfaction guaranteed**

You have plans, we will help you achieve them.  
*Any project. Any budget.*

## **Get a quote today!**

Call (732) 919-3339 or email sales@alltest.net.

**58503B**  
**GPS Time and Frequency**  
**Reference Receiver**  
**and**  
**59551A**  
**GPS Measurements**  
**Synchronization Module**  
  
**Getting Started Guide**

This guide describes how to install and begin to operate the 58503B GPS Time and Frequency Reference Receiver and 59551A GPS Measurements Synchronization Module via the RS-232C port(s). The information in this guide applies to instruments having the number prefix listed below, unless accompanied by a "Manual Updating Changes" package indicating otherwise.

**SERIAL PREFIX NUMBER: 3805A AND ABOVE (58503B)  
3805A AND ABOVE (59551A)**

Instruments with serial numbers below 3805A may have earlier versions of firmware installed. There are no operator-specific differences in previous versions of firmware.

**FIRMWARE REVISION: 3805A AND ABOVE (58503B)  
3805A AND ABOVE (59551A)**

Firmware revision can be identified by using a "\*IDN?" command sent to the Receiver via RS-232C port. See the section "Connecting to a Computer or Modem" in Chapter 2, "Features and Functions," in this guide for instructions on connecting a computer or modem to these products.

For assistance, contact:

Symmetricom, Inc.  
2300 Orchard Parkway  
San Jose, CA 95131-1017

U.S.A. Call Center:  
888-367-7966 (from inside U.S.A. only - toll free)  
408-428-7907

U.K. Call Center:  
+44.7000.111666 (Technical Assistance)  
+44.7000.111888 (Sales)  
+44.1604.586740

Fax: 408-428-7998

E-mail: [ctac@symmetricom.com](mailto:ctac@symmetricom.com)

Internet: <http://www.symmetricom.com>

#### Warning Symbols That May Be Used In This Book



Instruction manual symbol; the product will be marked with this symbol when it is necessary for the user to refer to the instruction manual.



Indicates hazardous voltages.



Indicates earth (ground) terminal.



or



Indicates terminal is connected to chassis when such connection is not apparent.

Indicates Alternating current.



Indicates Direct current.



---

# Contents

## In This Guide

<b>Guide Organization</b>	<b>vii</b>
<b>Description of the GPS Receivers</b>	<b>viii</b>
The 58503B GPS Time and Frequency Reference Receiver	viii
The 59551A GPS Measurements Synchronization Module	ix
<b>Options</b>	<b>x</b>
<b>Accessories Supplied and Available</b>	<b>x</b>
Accessories Supplied	x
Accessories Available	x
GPS Accessories	x
Serial Interface Accessories	xi
<b>Manuals</b>	<b>xii</b>
Supplied Manuals	xii

## 1 Getting Started

<b>58503B Front Panel at a Glance</b>	<b>1-2</b>
<b>58503B/Option 001 Front-Panel Display/Keypad at a Glance</b>	<b>1-3</b>
<b>58503B Rear Panel at a Glance</b>	<b>1-4</b>
<b>59551A Front Panel at a Glance</b>	<b>1-5</b>
<b>59551A Rear Panel at a Glance</b>	<b>1-6</b>
<b>Preparing the GPS Receiver for Use</b>	<b>1-7</b>
Installation Precautions	1-7
Electrostatic Precautions	1-7
Electromagnetic Considerations	1-7
To Install the Antenna System	1-7
To Connect Power	1-8
To Connect AC Power	1-8
To Assemble and Connect the XLR DC Power Connector/ Cable (Option AWQ for 58503B Only)	1-8
To Assemble and Connect the +129 Vdc IEC 320 Connector/ Cable (59551A Only)	1-9
<b>Connecting a Terminal or Computer to the GPS Receiver</b>	<b>1-12</b>
To Configure Terminal Communications for Windows NT <sup>®</sup> 4.0/ Windows <sup>®</sup> 95-Based PC	1-13
To Configure Terminal Communications for Windows <sup>®</sup> 3.1-Based PC	1-14
<b>Powering Up the Receiver</b>	<b>1-15</b>
Overview of the Power-Up Procedure (What to Expect)	1-15

To Power Up the Receiver	1-15
To Understand the Receiver Status Screen Data	1-17
<b>Installing the Automated SatStat Program for Continual Status Updates</b>	<b>1-18</b>
<b>Operating the Automated SatStat Program</b>	<b>1-19</b>
<b>Customizing the Receiver Operation</b>	<b>1-20</b>
<b>Using Commands to Control Key Functions (Examples)</b>	<b>1-21</b>
To Perform Basic Installation and Simple Customizing	1-21
If required, restore all of the Receiver's internal settings to their factory shipment values by invoking a system preset.	1-21
Initiate "surveying", an automatic determination of the Receiver's antenna position.	1-22
Set the Receiver's to compensate for the length of the antenna cable.	1-22
Set the Receiver's to exclude satellites which appear below a specified elevation angle.	1-23
Set the Receiver's to display local time rather than UTC time.	1-23
To Install With a Limited View of the Sky,	
To Bypass Position Survey Operation	1-23

## **2 Features and Functions**

<b>Chapter Contents</b>	<b>2-2</b>
<b>Inputs</b>	<b>2-4</b>
Antenna Input	2-4
Recommended Antenna Cable Assemblies	2-4
Antenna Cable Length Delay	2-5
POWER Input	2-7
58503B GPS Time and Frequency Reference Receiver	2-7
59551A GPS Measurements Synchronization Module	2-7
Time Tagging Inputs (59551A Only)	2-7
<b>Outputs</b>	<b>2-8</b>
1 PPS (One-Pulse-Per-Second) Output	2-8
1 PP2S (One-Pulse-Per-Two-Seconds) Option 002 Output (58503B Only)	2-8
Programmable Pulse Output (59551A Only)	2-8
IRIG-B Output (59551A Only)	2-8
Alarm BITE Output (59551A Only)	2-11
Alarm Output (58503B Only)	2-11
10 MHz OUT Output (58503B Only)	2-11

**Indicators 2-12**

- Power Indicator 2-12
- GPS Lock Indicator 2-12
- Holdover Indicator 2-12
- Alarm Indicator 2-12

**Serial Interface Port(s) 2-13**

- PORT 1 Rear-Panel RS-232C Serial Port 2-13
- PORT 2 Front-Panel RS-232C Serial Port (59551A Only) 2-14

**Connecting a Computer or Modem 2-15**

- To Connect the GPS Receiver to a PC, Laptop, or Modem Via the Rear-Panel PORT 1 2-16
  - Connecting to the Personal Computer (PC) 2-16
  - Connecting to a Modem 2-16
- To Connect the 59551A to a Laptop Computer Via the Front-Panel PORT 2 2-18

**Making Your Own Cables 2-19**

**Configuring the RS-232C Port(s) 2-20**

- Making Changes to the Serial Port Settings (If Needed) 2-21
  - Configuring PORT 1 of the 59551A 2-21
  - Configuring PORT 1 of the 58503B and PORT 2 of the 59551A 2-21
- Determining the Serial Port Settings 2-22
  - Standard 58503B and 59551A 2-22
  - Option 001 58503B 2-22

**Operating Concepts 2-23**

- General 2-23
- Holdover Description 2-23

**In Case of a Problem 2-24**

- Hours after powerup, Receiver not establishing GPS lock 2-24
- Receiver not maintaining GPS lock 2-25

**3 Using Option 001 Front-Panel Display/Keypad (58503B Only)**

**Chapter Contents 3-2**

**Overview 3-3**

- About the Display and Keypad 3-3
- Product Compatibility 3-3
- System Compatibility 3-3

**Using the Display and Keypad 3-4**

- To Display Time 3-4
- To Display Position 3-4

	Displaying Longitude	3-4
	Displaying Latitude	3-4
	Displaying Altitude	3-4
	To Display Number of Satellites Being Tracked	3-4
	To Display Serial Port Settings	3-5
	To Display System Status	3-5
	To Clear Instrument Alarm	3-5
	<b>Capabilities Under Special Circumstances</b>	<b>3-5</b>
	To Access the TEST MODE to Test the Front-Panel Display	3-5
	To Access the DEMO MODE to Demonstrate Front-Panel Capabilities	3-6
	To Check Serial Port Settings During Installation	3-6
	<b>Error Messages</b>	<b>3-7</b>
	<b>Status Messages</b>	<b>3-10</b>
<b>4</b>	<b>58503B Specifications</b>	
	<b>Specifications and Characteristics</b>	<b>4-2</b>
	GPS Receiver Features	4-2
	Other Information	4-5
	Options and Accessories	4-5
<b>5</b>	<b>59551A Specifications</b>	
	<b>Specifications and Characteristics</b>	<b>5-2</b>
	GPS Receiver Features	5-2
	Other Information	5-5
	Options and Accessories	5-5

## **Index**

---

# In This Guide

This preface contains the following information:

- Guide Organization page vii
- Description of the GPS Receivers page viii
- Options page x
- Accessories Supplied and Available page x
- Manuals page xii

---

## Guide Organization

### Table of Contents.

**In This Guide** (this preface) introduces you to the getting started guide, and provides general information on the 58503B and 59551A GPS Receivers.

Chapter 1, “**Getting Started**,” is a quick-start chapter that introduces you to the GPS Receivers with a brief overview of the GPS Receivers indicators and connectors. This chapter also provides installation, power-up instructions, and sample commands to familiarize you with the GPS Receivers.

Chapter 2, “**Features and Functions**,” provides information on GPS Receiver features and functions, connecting to computers, and problem solving (that is, a section titled “In Case of a Problem”).

Chapter 3, “**Using Option 001 Front-Panel Display/Keypad (58503B Only)**,” provides information on how to use the front-panel display and keypad option.

Chapter 4, “**58503B Specifications**,” lists the product specifications and characteristics.

Chapter 5, “**59551A Specifications**,” lists the product specifications and characteristics.

### Index

## Description of the GPS Receivers

### **The 58503B GPS Time and Frequency Reference Receiver**

The 58503B GPS Time and Frequency Reference Receiver provides highly accurate time and frequency outputs that can be used as a “house standard” to meet manufacturing, calibration, and development needs. The Receiver can also be used for synchronizing wireless base stations.

The Receiver provides highly accurate timing. If a satellite signal is lost, the Receiver automatically switches to holdover mode, which ensures system synchronization for up to 24 hours with reduced accuracy.

The standard 58503B has the following Input/Output connectors:

- an RS-232C serial communication port (25-pin female rectangular D subminiature on the rear panel)
- a 1 PPS output BNC
- an optional 1 PP2S output BNC (see page x and page 1-3)
- an Alarm output BNC
- 10 MHz output BNC
- an Antenna N-type connector
- Power input jack

The front panel contains four Light-Emitting-Diode (LED) indicators to indicate that power has been applied (**Power**), the module has tracked and locked on to one or more GPS satellites (**GPS Lock**), the GPS system is operating in holdover mode (**Holdover**), and an error or invalid condition exists due to system fault or reduced accuracy of the outputs (**Alarm**).

The standard 58503B has no front panel display or keypad entry. Information is remotely entered into and retrieved from the 58503B using a personal computer connected to the rear-panel 25-pin RS-232 port.

## The 59551A GPS Measurements Synchronization Module

The 59551A GPS Measurements Synchronization Module is a time synchronizing source primarily focused on the power industry's transmission protection and control applications for wide-area synchronization of the electric power transmission systems.

The Module provides highly accurate timing, and if a satellite signal is lost the Module automatically switches to holdover mode that ensures system synchronization for up to 24 hours with some loss of accuracy.

The module provides input/output connectors and ports for the generation of appropriate synchronization signals for a variety of transmission system requirements. Separate front and rear RS-232C ports allow external computers to be connected to the Module for analyzing data or entering commands without interrupting the output signals. Available time tagging inputs allow recording of time of occurrence of incoming edges (timestamping) for failure or sequence-of-events analysis.

The standard 59551A has the following Input/Output connectors:

- two RS-232C serial communication ports (9-pin female rectangular D subminiature on the front panel; 25-pin female rectangular D subminiature on the rear panel)
- an IRIG-B output BNC
- a 1 PPS output BNC
- an Alarm BITE output
- an Antenna N-type connector
- three Time-tag input BNCs
- Power input jack
- Programmable Pulse output BNC

The front panel contains four Light-Emitting-Diode (LED) indicators to indicate that power has been applied (**Power**), the module has tracked and locked on to one or more GPS satellites (**GPS Lock**), the GPS system is operating in holdover mode (**Holdover**), and an error or invalid condition exists due to system fault or reduced accuracy of the outputs (**Alarm**).

The 59551A has no front panel display or keypad entry. Information is remotely entered into and retrieved from the 59551A using a personal computer connected to the rear-panel 25-pin RS-232C port or the front-panel 9-pin RS-232C port.

## Options

- Option 1CM Rack Mount 483-millimeter
  - Option AXB Rack Mount 584-millimeter
  - Option AWQ DC Power Supply Auto Ranging (+24 or +48 Vdc) — 58503B only
  - Option 001 Front-Panel Display/Keypad — 58503B only
  - Option 002 1 PP2S Output — 58503B only
- 

## Accessories Supplied and Available

### Accessories Supplied

SatStat Program P/N 59551-13401

IEC 320 DC Connector Plug P/N 1252-5672

### Accessories Available

#### *GPS Accessories*

Refer to the subsections titled “Recommended Antenna Cable Assemblies” and “Antenna Cable Length Delay” in Chapter 2 of this guide for more cable information.

- 58532A L1 Reference Antenna
- 58538A Lightning Arrestor
- 58539A Lightning Arrestor
- 58529A Antenna Line Amplifier with L1 Bandpass Filter (recommended for distances greater than 53.3 meters for RG-213 cable; 61 meters for LMR cable)
- 58530A GPS L1 Bandpass Filter
- 58518A RG-213 Antenna Cable Assembly (1 to 50 meters)— TNC-to-N connectors
- 58519A RG-213 Interconnect Cable Assembly (1 to 50 meters)— N-to-N connectors

- 58520A LMR 400<sup>1</sup> Antenna Cable Assembly (1 to 110 meters)—TNC-to-N connectors
- 58521A LMR 400<sup>1</sup> Interconnect Cable Assembly (1 to 110 meters)—N-to-N connectors
- 58518AA<sup>2</sup> RG-213 Antenna Cable Assembly (1 to 50 meters)—without connectors attached
- 58519AA<sup>2</sup> RG-213 Interconnect Cable Assembly (1 to 50 meters)—without connectors attached
- 58520AA<sup>2</sup> LMR 400<sup>1</sup> Antenna Cable Assembly (1 to 110 meters)—without connectors attached
- 58521AA<sup>2</sup> LMR 400<sup>1</sup> Interconnect Cable Assembly (1 to 110 meters)—without connectors attached

### ***Serial Interface Accessories***

- DTE-to-DTE 25-Pin (m) to 9-pin (f) RS-232 Interface Cable
- DTE-to-DTE 9-Pin (f) to 9-pin (f) RS-232 Interface Cable
- DTE-to-DCE 25-Pin (m-to-f) RS-232 Interface Cable

---

<sup>1</sup> LMR 400 cables are low-loss, less flexible than RG-213, but very good coaxial cables.

<sup>2</sup> These cables do not have the connectors attached. A connector kit is supplied.

## Manuals

### **Supplied Manuals**

The following guides that document the 58503B and 59551A are shipped with the product.

- 58503B/59551A Getting Started Guide (this guide),  
P/N 097-58503-12
- 58503B/59551A Operating and Programming Guide,  
P/N 097-58503-13

---

1

---

Getting Started

---

## 58503B Front Panel at a Glance

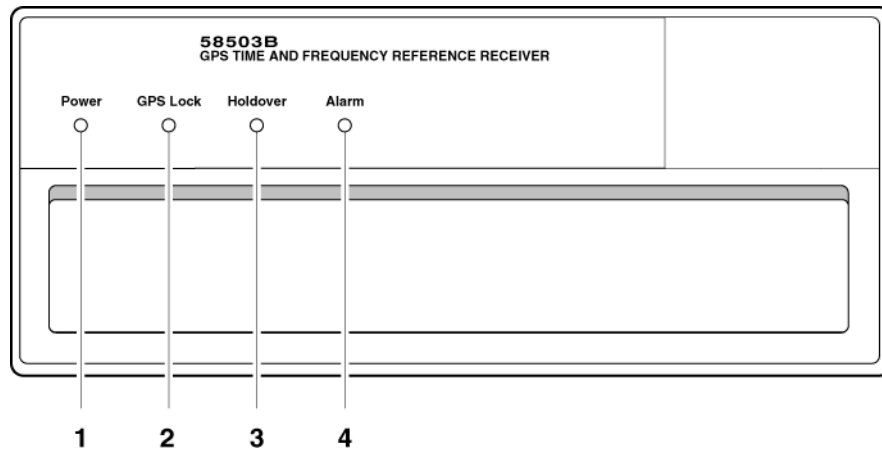

- 1 When the **Power** indicator illuminates, it indicates that the proper input power is supplied to the Receiver.
- 2 When the **GPS Lock** indicator illuminates, it indicates that the Receiver is receiving the GPS signal and is locked on one or more satellite(s).
- 3 When the **Holdover** indicator illuminates, it indicates that the Receiver is NOT locked to the GPS signal. The Receiver is keeping time based on the internal reference oscillator signal. The internal reference oscillator will determine the accuracy of the 1 PPS signal and the 10 MHz reference output.
- 4 When the **Alarm** indicator illuminates, it indicates that the Receiver has detected an internal condition that requires attention.

---

## 58503B/Option 001 Front-Panel Display/Keypad at a Glance

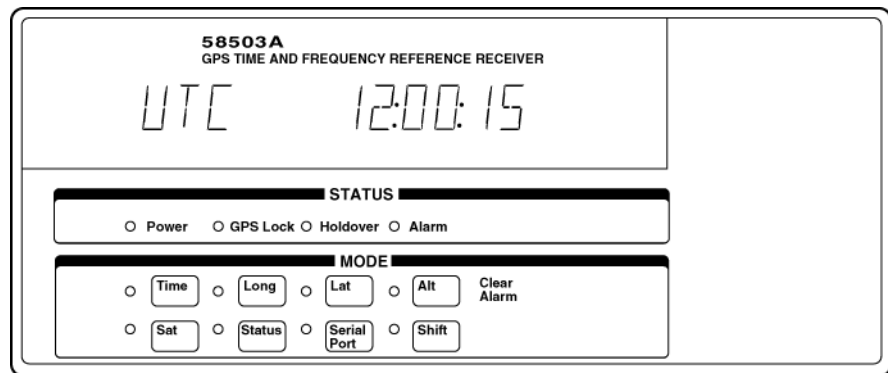

**1** An alphanumeric display for displaying time, position (i.e., longitude, latitude, and altitude), and Receiver status. The display is a highly visible twelve-character vacuum-fluorescent display.

**2** **Status** LED indicators:

When the **Power** indicator is illuminated, it indicates that input power is supplied to the Receiver.

When the **GPS Lock** indicator is illuminated, it indicates that the Receiver is tracking satellites and has phase-locked its internal reference to the reference provided by GPS.

When the **Holdover** indicator is illuminated, it indicates that the Receiver is not phase-locking its internal reference to the reference provided by GPS. Typically, this would happen due to loss of satellite tracking.

When the **Alarm** indicator is illuminated, it indicates that the Module has detected a condition that requires attention.

**3** Eight **MODE** keys with associated LEDs for front-panel access to time, position, and status information: **Time**, **Long** (longitude), **Lat** (latitude) **Alt** (altitude), **Sat** (number of satellites tracking), **Status** (Receiver or system status), and **Serial Port** (serial port settings). Each key selects a different display mode. Also, pressing **Shift** and **Alt** key in sequence clears instrument alarm.

## 58503B Rear Panel at a Glance

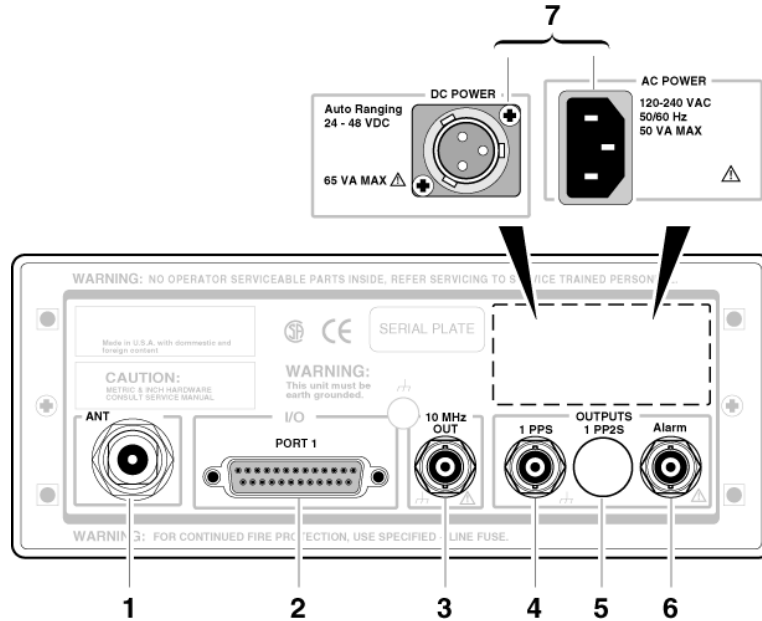

- 1 **ANT** N-type (female) connector for GPS Antenna connection.
- 2 **PORT 1** RS-232C, DB-25 (female) serial interface port for remote control, monitoring, and downloading of the Receiver's memory data and upgrading Receiver software.
- 3 **10 MHz OUT** output for user-specific applications.
- 4 **1 PPS** connector for outputting a continuous 1 Pulse Per Second signal.
- 5 **Option 002 1 PP2S** (One-Pulse-Per-Two-Seconds) connector for outputting a pulse every other second, synchronized to the even seconds in GPS time. Pulses occur on even-numbered seconds (i.e., 2 seconds, 4 seconds, etc.).
- 6 **Alarm** output for external devices (such as red light, bell, or horn) to indicate that the Receiver has detected an internal condition that requires attention.
- 7 **POWER** input jack.

---

## 59551A Front Panel at a Glance

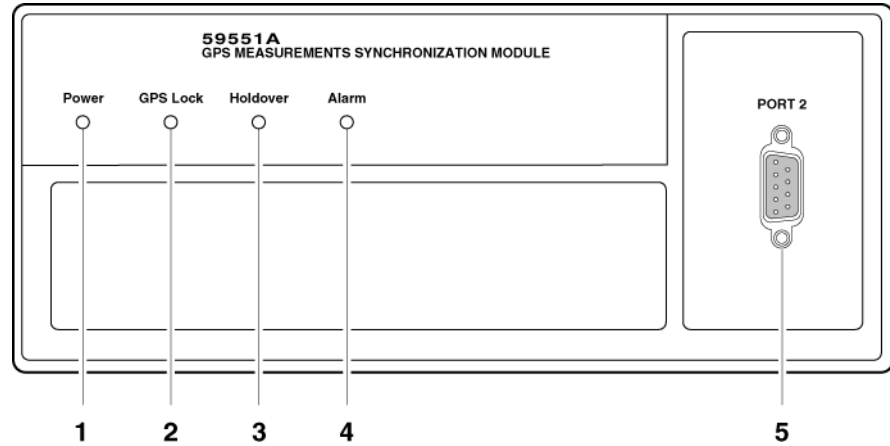

- 1 When the **Power** indicator illuminates, it indicates that the proper input power is supplied to the Module.
- 2 When the **GPS Lock** indicator illuminates, it indicates that the Module is receiving the GPS signal and is locked on one or more satellite(s).
- 3 When the **Holdover** indicator illuminates, it indicates that the Module is NOT locked to the GPS signal. The Module is keeping time based on the internal reference oscillator signal. The internal reference oscillator will determine the accuracy of the 1 PPS signal.
- 4 When the **Alarm** indicator illuminates, it indicates that the Module has detected an internal condition that requires attention.
- 5 **PORT 2** RS-232C, DE-9S (female) serial interface port for local monitoring and retrieving data stored in the Module's memory data.

---

## 59551A Rear Panel at a Glance

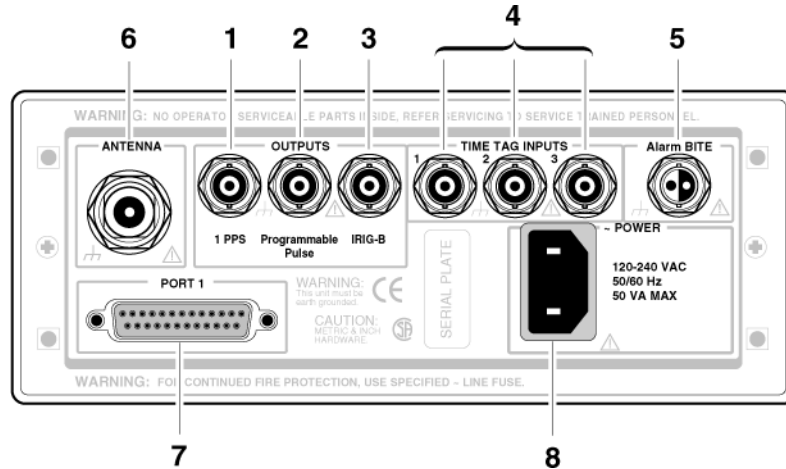

- 1 1 PPS** (One-Pulse-Per-Second) connector for outputting a continuous one pulse per second signal.
- 2 Programmable Pulse** output connector for outputting pulses at user-specified time/period.
- 3 IRIG-B** output for outputting formatted time-code signals. (This signal is used for general purpose time distribution and magnetic tape annotation applications requiring the time of year.)
- 4 Time tag** input connectors for receiving TTL conditioned time tagging signals.
- 5 Alarm BITE** (Built-In Test Equipment) output for external devices (such as red light, bell, or horn) to indicate that the Module has detected an internal condition that requires attention. The relay opens and closes with the **Alarm** indicator. (Mating connector is Amphenol part number 31-224 [glass-filled Noryl] or #31-2226 [Telfon]).
- 6 ANTENNA** N-type (female) connector for GPS antenna connection.
- 7 PORT 1** RS-232C, DB-25 (female) serial interface port for remote control, monitoring, and retrieving of the Module's memory data and upgrading Module software.
- 8 AC POWER** input jack. The AC input jack is standard. The unit operates from ac voltage. It can also be operated from dc voltage via this ac jack by using the supplied IEC 320 dc connector plug.

## Preparing the GPS Receiver for Use

### Installation Precautions

Before you install the 58503B or 59551A, please review the following precautions and considerations.

#### *Electrostatic Precautions*

Parts and assemblies inside of the 58503B and 59551A Receivers may be sensitive to damage by electrostatic discharge (ESD). The Receivers contain a very sensitive RF receiver. Please use ESD precautionary procedures when connecting and removing the antenna.

#### *Electromagnetic Considerations*

The 58503B and 59951A Receivers contain a very sensitive RF receiver. You must observe certain precautions to prevent possible interference from strong electromagnetic sources, such as nearby transmitters and antennas. Because the electronic magnetic environment will vary for each application and antenna installation, it is not possible to define exact guidelines to assure electromagnetic compatibility.

If interference is suspected, relocation of the GPS antenna usually solves the problem. In worst case situations, additional RF filtering may be required.

### To Install the Antenna System

***CABLE CONSIDERATIONS.*** *When using the antenna cables with the GPS Receivers, you should observe certain precautions. Consult your local electrical and building ordinance codes on how to install RG-213 cables (58518A/519A) or LMR 400 cables (58520A/521A). Certain codes might require you to put the cables inside a conduit, or to use cables made with a non-toxic fire retardant insulation.*

To assist you with installing your GPS antenna system, refer to the following documents:

- *Designing Your GPS Antenna System Configuration Guide*, which discusses the components of an GPS timing receiver system and how to custom design the configuration of your antenna system. *Contact your local Sales office for a copy of this guide.*
- Information Notes that provide installation procedures for the applicable GPS antenna and accessories that you purchase.

## Preparing the GPS Receiver for Use

- The subsection titled “Antenna Input” in Chapter 2, “Features and Functions” of this guide.

### To Connect Power

#### *To Connect AC Power*

The ac power module or jack senses incoming voltage and automatically selects the proper setup. Just connect the Receiver to the ac power source using the supplied power cord.

#### *To Assemble and Connect the XLR DC Power Connector/Cable (Option AWQ for 58503B Only)*

- 1 Note that you will have to assemble your own dc power cable using 18 AWG connecting wires and a three-pin XLR (female) connector plug (shown in Figure 1-1).

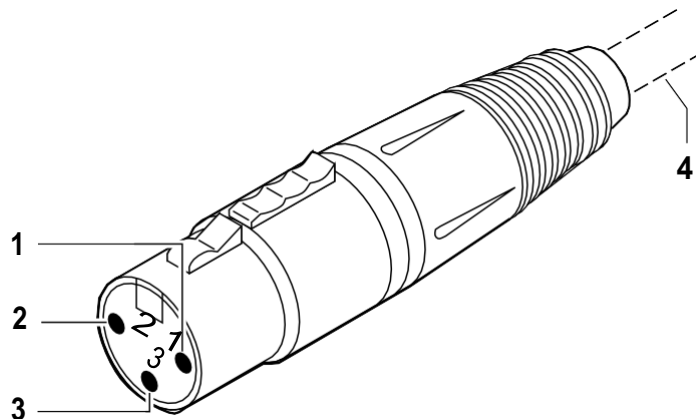

- |                 |                                   |
|-----------------|-----------------------------------|
| 1 dc supply (+) | 3 Chassis ground                  |
| 2 dc return (-) | 4 Cable wires (customer supplies) |

**Figure 1-1. Three-Pin XLR Plug Pinouts (Front View)**

- 2 From the rear of the XLR plug, connect the supply-side wire of the external power supply or battery to pin 1 of the XLR plug. Connect the external battery’s return (ground) wire to pin 2, and the chassis ground wire to pin 3 of the XLR plug.
- 3 Observing the correct polarity, attach the other ends of the wires to a proper dc power source to operate the Receiver.

## Preparing the GPS Receiver for Use

### ***To Assemble and Connect the +129 Vdc IEC 320 Connector/ Cable (59551A Only)***

The 59551A is operated from ac voltage. It can also be operated from 129 Vdc. Note that you will have to assemble your own dc power cable using 18 AWG connecting wires and the supplied IEC 320 dc connector plug as shown in Figure 1-2A.

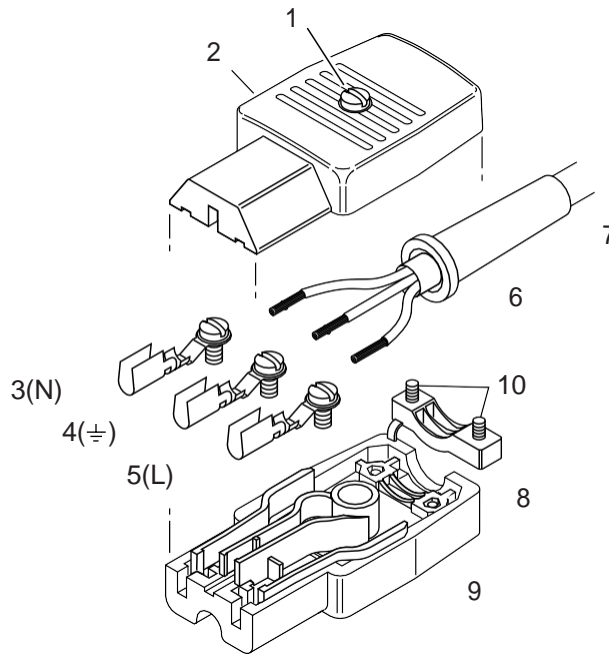

- |   |                                    |
|---|------------------------------------|
| <b>1</b> Cover screw                      | <b>6</b> Cable sleeve              |
| <b>2</b> Top cover                        | <b>7</b> Cable (customer supplies) |
| <b>3</b> Negative (low voltage) terminal  | <b>8</b> Wire clamp                |
| <b>4</b> Chassis ground terminal          | <b>9</b> Bottom cover              |
| <b>5</b> Positive (high voltage) terminal | <b>10</b> Wire clamp screws        |

### **Figure 1-2A. 129 Vdc IEC 300 DC Connector Plug and Power Cable Exploded View**

- 1** Using a small flat blade screwdriver, open the the connector by loosening the cover center screw (**1**)that holds two cover (**2, 9**) of the connector plug together Figure 1-2A.
- 2** Using a small flat blade screwdriver, pry loose contact terminals **3, 4,** and **5** from the bottom cover (**9**)of the connector plug.

**Preparing the GPS Receiver for Use**

- 3** Slide the cable sleeve (**6**) over the cable (**7**).
- 4** Loosen the screw of **5 (L)** terminal, and connect the positive (high) voltage wire to the terminal.  
  
The “L” terminal marking is inscribed inside the bottom cover (**9**).
- 5** Tighten screw. Soldering is not necessary.
- 6** Loosen the screw of **3 (N)** terminal, and connect the negative (low) voltage wire to the terminal.  
  
The “N” terminal marking is inscribed inside the bottom cover (**9**).
- 7** Tighten screw. Soldering is not necessary.
- 8** Loosen the screw of **4 (⊕)** terminal, and connect the ground (chassis) wire to the terminal.  
  
The “⊕” terminal marking is inscribed inside the bottom cover (**9**).
- 9** Tighten screw. Soldering is not necessary.
- 10** With the wires connected to the terminals (**3, 4, and 5**), re-insert the terminal in their proper positions in the bottom cover (**9**).
- 11** Make sure that the cable sleeve’s (**6**) brim is placed in the groove or slot in the bottom cover (**9**).
- 12** Clamp the wires down using the wire clamp (**8**). Position the clamp and over the wires and attach and secure it to bottom cover (**9**) by tightening the two screws (**10**).

At this point, your connector plug and cable assembly should look similar to Figure 1-2B.

**Preparing the GPS Receiver for Use**

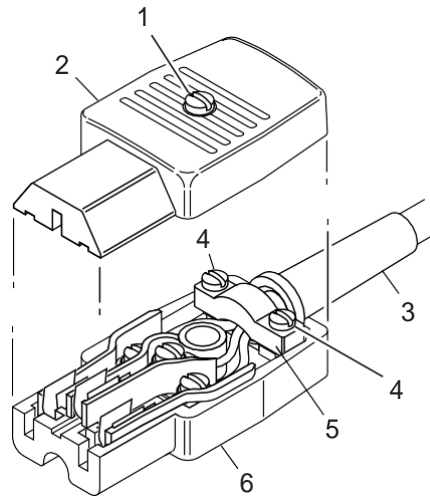

- |                       |                            |
|-----------------------|----------------------------|
| <b>1</b> Cover screw  | <b>4</b> Wire clamp screws |
| <b>2</b> Top cover    | <b>5</b> Wire clamp        |
| <b>3</b> Cable sleeve | <b>6</b> Bottom cover      |

**Figure 1-2B. 129 Vdc DC Power Cable Assembly**

- 13** As shown in Figure 1-2B, join the two covers (**2, 6**) by properly positioning them together and tightening the wire clamp screws (**4**).
- 14** Finally, secure the two covers by tightening the cover screw (**1**).
- 15** Observing the correct polarity, attach the other ends of the wires to a proper dc power source to operate the Module.

---

## Connecting a Terminal or Computer to the GPS Receiver

---

**NOTE**

The GPS Receiver may be operated without a terminal or computer. The computer is needed for you to observe the progress of the GPS Receiver or to configure alarms, or to change setup parameters.

- 1 For the procedures in this chapter, connect the computer to the rear-panel RS232C (**PORT 1**) port using 25-pin male to 9-pin female RS-232 null-modem cable as shown in Figure 1-3.

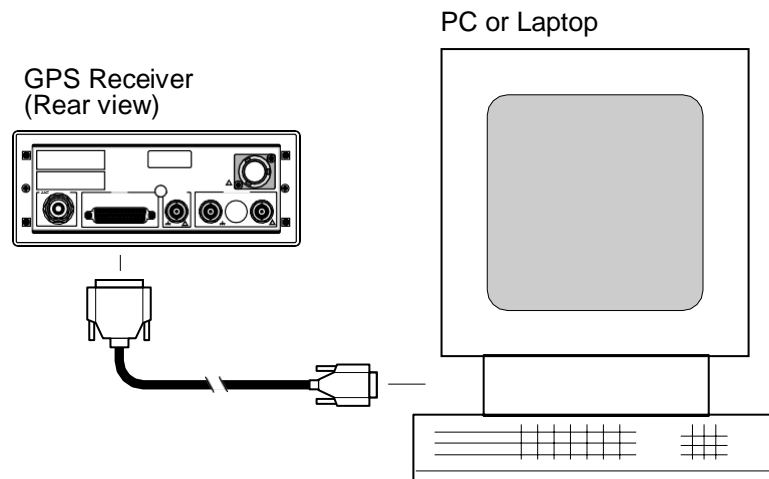

**Figure 1-3. Connecting a PC or Terminal to the GPS Receiver**

*You will need to run a terminal emulation program on your PC in order to communicate via the RS-232C serial port. Most PCs contain a terminal emulation program, especially PCs with Windows. If your PC does not contain a terminal emulation program, purchase one of the following programs: PROCOMM PLUS (DATASTORM Technologies, Inc.®), PROCOMM PLUS for Windows, Cross Talk (Hayes®), or any other terminal emulation program.*

- 2 *If you are using a Windows NT® 4.0-based or Windows® 95-based PC, perform the procedure below in the subsection “To Configure Terminal Communications for Windows NT® 4.0/Windows® 95-Based PC.”*

OR

## Connecting a Terminal or Computer to the GPS Receiver

*If you are using a Windows<sup>®</sup> 3.1-based PC, perform the procedure in the subsection “To Configure Terminal Communications for Windows<sup>®</sup> 3.1-Based PC” on page 1-14.*

### To Configure Terminal Communications for Windows NT<sup>®</sup> 4.0/Windows<sup>®</sup> 95-Based PC

- 1 In the Windows NT (or Windows 95) main window, click the **Start** button then select **Programs**.

- 2 Select **Accessories**, **Hyperterminal**, and **Hyper Terminal**.

The **Connection Description** dialog box is displayed.

- 3 In the “Name” window, type **58503B** (for example), select one of the icons (the first one will do), then click **OK**.

The **Connect To** dialog box is displayed.

- 4 In the “Connect using” window, select the appropriate port or connector (COM1 or COM2), then click **OK**.

The **COM1** (or **COM2**) **Properties** dialog box is displayed. This dialog box allows you to configure the RS-232 port of your PC.

- 5 Set the RS-232 port of your PC to match the following default values:

Baud rate (Bits per second): 9600

Parity: None

Data bits: 8

Stop bits: 1

Pace (flow control): None

---

#### **NOTE**

The RS-232C port configurations of the GPS Receiver and the PC must be the same for communications between the two. If the GPS Receiver is being powered up for the first time, set your PC to match the factory default values listed above.

If an error-number prompt (**E-xxx>**) or no **scpi>** prompt is displayed after pressing Return (or Enter) on your PC, the default values of the GPS Receiver have been modified. See the subsections “Making Changes to the Serial Port Settings (If Needed)” and “Determining the Serial Port Settings” in Chapter 2 for more information.

- 6 Click **OK**.

**Connecting a Terminal or Computer to the GPS Receiver**

- 7 Next, perform the power-up procedure described in the section “Powering Up the Receiver” on page 1-15.

**To Configure Terminal Communications for Windows® 3.1-Based PC**

- 1 Select or double click on the Terminal icon (a picture of a PC with a telephone in front of it) in the Accessories window.
- 2 Select **Settings**, then choose **Communications**.

A dialog box is displayed that allows you to configure your PC.

- 3 Set the RS-232 port of your PC to match the following default values:

Pace:	None
Baud Rate:	9600
Parity:	None
Data Bits:	8
Stop Bits:	1

---

**NOTE**

---

See the important NOTE on page 1-13 that provides information on what to do if the factory-default values of the GPS Receiver’s RS-232C port have been changed.

- 4 In the **Communications** dialog box, be sure to select the appropriate port or connector (COM1, for example).
- 5 Next, perform the power-up procedure described in the section “Powering Up the Receiver” on page 1-15.

## Powering Up the Receiver

### **Overview of the Power-Up Procedure (What to Expect)**

When you power up the GPS Receiver for the first time, you should expect it to run through the following sequence:

- goes through internal diagnostics and all front-panel lights flash,
- acquires and tracks at least four satellites,
- computes the Receiver's position,
- locks to the 1 PPS (one pulse-per-second) time standard provided by GPS, and
- begins steady-state operation, acting as a source of timing information derived from the GPS standard.

Elapsed time for each step will vary, depending largely on how many satellites your antenna is able to “see” when you power up. If many satellites are visible when you power up, the Receiver will take at least 8 minutes and at most 25 minutes to calculate its position from the constellation of satellites overhead. The derived position will be improved over a period of time by further averaging. When the **GPS Lock** indicator lights, the basic functionality of the Receiver is available; however, optimal performance is delivered later.

### **To Power Up the Receiver**

- 1** Connect the antenna system to the rear-panel **ANTENNA** Type-N connector of the Receiver as described in the instructions given in the subsection “To Install the Antenna System” on page 1-7 of this chapter

---

#### **NOTE**

Do not apply power to the Receiver unless a fully operational antenna system is connected to the rear-panel ANTENNA input connector. Power applied with no antenna input can initiate an extended search process that may increase time to reach GPS lock. *You can halt the extended search by disconnecting and reconnecting (cycling) the external supplies of the GPS Receivers (you may need to leave power off for greater than five seconds).*

---

## Chapter 1 Getting Started

### Powering Up the Receiver

- 2 Apply the proper power source to the rear-panel **Power** input jack of the Receiver.

See the appropriate subsection “To Assemble and Connect the XLR DC Power Connector/Cable (Option AWQ for 58503B Only)” or “To Assemble and Connect the +129 Vdc IEC 320 Connector/ Cable (59551A Only)” on page 1-9.

The following sequence of events occurs after power is applied to the Receiver.

- a. Only the front-panel **Power** indicator lights.
- b. After a moment, the Receiver runs through its self-test diagnostics as indicated by the flashing front-panel indicators.
- c. After the self-test is completed, just the **Power** indicator remains illuminated.

If the **Alarm** indicator lights, a failure may have occurred during the self-test. See the section “Operating Status” in Chapter 5, “Command Reference,” of the *58503B/59551A Operating and Programming Guide* (58503-90013) for a complete description of the Alarm capability.

- d. The Receiver begins to search the sky for all available satellites.
- e. From the computer keyboard, type

:SYSTEM:STATUS? and press Enter (or Return).

If you typed in the command wrong a **E-xxx>** prompt is displayed after pressing Return. Try typing in the command again.

The computer displays the status screen as shown in the sample status screen in Figure 1-4 on page 1-17.

**You must re-enter the :SYSTEM:STATUS? command each time you want an updated status screen.**

---

#### **NOTE**

You have been provided a Windows program called SatStat, which provides *continual status updates* of the GPS Receiver’s status screen. This program will have to be run by a personal computer (PC) that has Windows<sup>®</sup>, or Windows<sup>®</sup> 95, or NT<sup>®</sup> 4.0 installed to operate it. The program is easy to install and operate.

See the section titled “Installing the Automated SatStat Program for Continual Status Updates” on page 1-18 in this guide.

---

## Chapter 1 Getting Started

### Powering Up the Receiver

```

Receiver Status
-----
SYNCHRONIZATION ..... [ Outputs Valid ]
SmartClock Mode ..... Reference Outputs
>> Locked to GPS ..... TFOM 3 FFOM 0
Recovery ..... 1PPS TI +7.2 ns relative to GPS
Holdover ..... HOLD THR 1.000 us
Power-up ..... Holdover Uncertainty
Predict 49.0 us/initial 24 hrs

ACQUISITION ..... [GPS 1PPS Valid]
Tracking: 6 Not Tracking: 1
PRN El Az C/N PRN El Az Time +1 leap second pending
2 49 243 49 14 11 82 UTC 23:59:59 31 Dec 1995
16 24 282 44 GPS 1PPS Synchronized to UTC
18 38 154 49 ANT DLY 120 ns
19 65 52 43 Position
27 62 327 44 MODE Survey: 17.5% complete
31 34 61 38
AVG LAT N 37:19:32.264
AVG LON W 121:59:52.112
ELEV MASK 10 deg AVG HGT +41.86 m (GPS)
HEALTH MONITOR ..... [ OK ]
Self Test: OK Int Pwr: OK Oven Pwr: OK OCXO: OK EFC: OK GPS Rcv: OK

```

**Figure 1-4. Sample Status Screen (58503B screen shown)**

If you need to customize the Receiver operation, see the section titled “Customizing the Receiver Operation” on page 1-20 for a list of key things you may want to perform to customize the operating parameters of the Receiver.

### To Understand the Receiver Status Screen Data

One of the key indicators on the screen is the **ACQUISITION** status indicator. It shows “GPS 1 PPS Valid” as soon as satellite information is sufficient.

Refer to Chapter 3, “Visual User Interface,” in the *58503B/59551A Operating and Programming Guide* for a tutorial on how to use the status screen (shown in Figure 1-4). This chapter of the operating and programming guide also provides a reference section that defines the different data indicated in the status screen.

---

## Installing the Automated SatStat Program for Continual Status Updates

This Windows program provides, among other things, continual status updates of the GPS Receiver or Receiver Status screen. Your PC must have Windows<sup>®</sup>, or Windows<sup>®</sup> 95, or Windows NT<sup>®</sup>4.0 installed to operate the program. The program is easy to install and operate.

- 1 Insert the SatStat disk into the 3.5-inch disk drive (or **A:** drive).
- 2 If using Windows 95 or NT, start Windows, open Windows Explorer, and double-click on the **A:** drive and then the **setup.exe** file to install the SatStat program. The SatStat Setup screen will appear, and installation will proceed. Next, perform step 3.

or

If you are using Windows 3.1, get into either Program Manager or File Manager. Then perform the following:

- a. Select File menu, and choose Run.
  - b. Type **a:setup**, and click **OK** or press Enter (Return). The SatStat Setup screen will appear, and installation will proceed.
- 3 Once the program is installed, you can start it by double-clicking the **SatStat** icon that was created during the installation.
  - 4 You should establish communication with the Receiver. This requires connection from a serial RS-232 port on your PC to the GPS Receiver's **PORT 1** port. Assuming you've got the cable attached to make this connection, you may want to check the settings.

- a. Select **CommPort**, then choose **Settings**.

The Communication Settings dialog box is displayed. Unless someone has reprogrammed the CommPort settings on the GPS Receiver, these settings are probably OK. *The one setting that is likely to need changing is the Com Port. The application defaults it to Com1, but the serial port on your PC may be assigned to a different Com Port. Select the appropriate setting. If you are unsure, Com1 will be your best bet (worst case, you can cycle through all of them until it works).*

- b. If you made any changes on this Settings form, select **OK**, otherwise you can just **Cancel**.

---

## Operating the Automated SatStat Program

- 1 Select **CommPort**, then choose **Port Open**.

The main form of the Receiver Status screen is displayed. The program will send some commands to the Receiver and then the main form should begin to periodically update every few seconds. If you are getting screen updates, proceed to the next step. Otherwise, something is wrong with your CommPort settings or perhaps the physical connection between your PC and the Receiver.

If you need to control the Receiver or query for the status of a setting of the Receiver, use the “Control & Query” form (this form will usually be stacked beneath the main form). To activate this form, click anywhere on it. Select **Control** (or **Query**), then choose the type of control (or query) you want. This will pull down a list of control (or query) functions that you can choose from, and the corresponding command will be displayed. To send the command, click on **Send Cmd**. Hence, with the Control & Query form you can control the Receiver without knowing the command or query.

More information about the Windows program is provided in the “Getting Started” Help file.

- 2 Refer to Chapter 3, “Visual User Interface,” in *58503B/59551A Operating and Programming Guide* for a tutorial and demonstration of what to look for when viewing the status screen.

## Customizing the Receiver Operation

Here are some things you might want to do to customize the Receiver operation:

- Execute a system preset if someone else has used the Receiver and left it in an unacceptable state.
- Make the Receiver survey if it wasn't already surveying.
- Set the antenna delay.
- Set the elevation mask angle.
- Set the time zone.

See the section titled "Using Commands to Control Key Functions (Examples)" on the following page for more information.

## Using Commands to Control Key Functions (Examples)

The operation of the Receiver is designed to be as automatic as possible. However, there are situations where serial interface control could be required. The tasks described here are those most commonly encountered.

For each task in this section, you can use either a terminal emulation program or the SatStat program to issue the selected commands. Additional information about the SCPI commands is provided in the *58503B/59551A Operating and Programming Guide*.

### **To Perform Basic Installation and Simple Customizing**

After connecting the Receiver to the antenna, power source, RS-232 port, and after the self test is completed, you may want to complete installation using one or more of the capabilities described below.

***If required, restore all of the Receiver's internal settings to their factory shipment values by invoking a system preset.***

After executing the system preset, the Receiver will begin normal operation: it will acquire GPS signals, determine the date, time, and position automatically, bring the reference oscillator ovens to a stable operating temperature, lock the reference oscillator and its output to 10 MHz, and synchronize the 1 PPS output to UTC.

Setting of SCPI commands affected by system preset are listed in *58503B/59551A Operating and Programming Guide*.

The Receiver is preset using the command:

```
:SYSTEM:PRESET
```

Note that system preset should be performed only when necessary.

**Using Commands to Control Key Functions (Examples)**

***Initiate “surveying”, an automatic determination of the Receiver’s antenna position.***

When “position survey” is invoked, the Receiver is set to ascertain the position of its antenna automatically. This survey is important; correct antenna position data is required for the Receiver to deliver specified performance.

The Receiver uses data from orbiting satellites to survey; hence, the antenna must be installed and operational for the survey to work. However, if you have a limited view of the sky, you can complete basic installation, then read forward to the section titled “To Install With a Limited View of the Sky, To Bypass Position Survey Operation” on page 1-23 for a means of overriding the survey operation and entering position data directly.

The survey is an iterative process. The Receiver transits to “Position Hold” after it has suitably refined its position estimate.

Set the Receiver to survey using command:

```
:GPS:POSITION:SURVEY ONCE
```

***Set the Receiver’s to compensate for the length of the antenna cable.***

The Receiver can be custom-configured to compensate for the length of the antenna cable. The phase of the Receiver’s internal clock is offset by the value you enter with this command. The amount of error is typically on the order of a few hundred nanoseconds. Should you decide to correct for this error, tables 2-1 and 2-2 in Chapter 2, “Features and Functions,” of this guide provides typical corrections for standard antenna cable lengths.

Set the Receiver to compensate for antenna cable delay using the command:

```
:GPS:REFERENCE:ADELAY <seconds>
```

It is normal to observe that the Receiver momentarily goes into holdover after any change in antenna delay.

## Using Commands to Control Key Functions (Examples)

### ***Set the Receiver's to exclude satellites which appear below a specified elevation angle.***

At the factory, and whenever the Receiver is preset, the Receiver is set to seek satellites 10 degrees above the horizon—down to an “elevation mask angle” of 10 degrees. The 10 degrees setting provides a view of most of the sky while avoiding near-horizon satellites, which are more susceptible to atmospheric anomalies and multi-path effects. The Receiver can be custom-configured to use a different elevation mask angle.

Set the Receiver elevation mask angle using the command:

```
:GPS:SAT:TRAC:EMANGLE <degrees>
```

### ***Set the Receiver's to display local time rather than UTC time.***

Set the offset from UTC time to local time using the command:

```
:PTIME:TZONE <hours>, <minutes>
```

## **To Install With a Limited View of the Sky, To Bypass Position Survey Operation**

In order to operate properly, the Receiver must know its position. The Receiver is able to collect enough information from four satellites to compute this position. The “position survey operation” takes in data from the satellites, iterating until the antenna position is known to the required precision. The Receiver will automatically use its position survey operation on powerup and :SYSTEM:PRESET.

Alternatively, if the antenna position is already known to seconds of arc, and the Receiver cannot see enough satellites, you may manually enter antenna position as shown in the following text.

---

**NOTE**

---

An incorrect value for the position will confuse the Receiver, and will degrade the timing information accuracy or even prevent tracking any satellites.

Set the Receiver antenna position using the command format shown below (For clarity, an example is provided rather than a complex description.):

```
:GPS:POS N,37,19,32.5,W,121,59,51.2,40.12
```

**Using Commands to Control Key Functions (Examples)**

Set the latitude, longitude, and height parameters to represent the latitude (in degrees, minutes, seconds), longitude (in degrees, minutes, seconds), and altitude in meters above the GPS ellipsoid for the 58503B (altitude in meters above mean sea level (MSL) for the 59551A). (Note: if you know the position to this accuracy, the desired position is of the antenna rather than the Receiver.)

---

***NOTE***

---

For faster acquisition following repair, or power failure you may want to write down the position after the Receiver has completed its survey.



---

## Chapter Contents

You will find that this chapter makes it easy to look up details about a particular feature of the GPS Receiver.

This chapter is organized as follows:

• Inputs	page 2-4
– Antenna Input	page 2-4
– POWER Input	page 2-7
• Outputs	page 2-8
– 1 PPS (One-Pulse-Per-Second) Output	page 2-8
– 1 PP2S (One-Pulse-Per-Two-Seconds) Option 002 Output (58503B Only)	page 2-8
– Programmable Pulse Output (59551A Only)	page 2-8
– IRIG-B (59551A Only)	page 2-8
– Alarm BITE Output (59551A Only)	page 2-11
– Alarm Output (58503B Only)	page 2-11
– 10 MHz OUT Output (58503B Only)	page 2-11
• Indicators	page 2-12
– Power Indicator	page 2-12
– GPS Lock Indicator	page 2-12
– Holdover Indicator	page 2-12
– Alarm Indicator	page 2-12
• Serial Interface Ports	page 2-13
– PORT 1 Rear-Panel RS-232C Serial Port	page 2-13
– PORT 2 Front-Panel Serial Port (59551A Only)	page 2-14
• Connecting to a Computer or Modem	page 2-13
– To Connect the GPS Receiver to a PC, Laptop, or Modem Via the Rear-Panel PORT 1	page 2-16
– To Connect the 59551A to a Laptop Computer Via the Front-Panel PORT 2	page 2-16
• Making Your Own Cables	page 2-19
• Configuring the RS-232C Port(s)	page 2-20
– Making Changes to the Serial Port Settings (If Needed)	page 2-21
– Determining the Serial Port Settings	page 2-22

**Chapter Contents**

• Operating Concepts	page 2-23
- General	page 2-23
- Holdover Description	page 2-23
• In Case of a Problem	page 2-24

---

## Inputs

### **Antenna Input**

The N-type (female) **ANTENNA** connector allows you to connect to the 58532A L1 Reference Antenna. The antenna assembly is an “active” antenna; a “passive” antenna will not work with the Receiver.

Integral to the antenna assembly is a low noise amplifier (LNA) that is provided for Receiver operation with antenna cable lengths up to 115.2 meters for LMR 400 cables or 53.3 meters<sup>1</sup> for RG-213 cables. The single coax cable is used to provide signals from the antenna to the Receiver and to supply a dc voltage to the LNA. For longer antenna feed runs, an additional amplifier (58529A Antenna Line Amplifier) is required to compensate for lengths greater than 115.2 meters or 53.3 meters.

### ***Recommended Antenna Cable Assemblies***

There are two types of cable assemblies recommended for connecting your antenna system: LMR 400 or RG-213 (Belden® 8267 ).

The following paragraphs describes when and how many line amplifiers are required with the LMR 400 and RG-213 cables.

### **LMR 400 Cable Line Amplifier Requirements**

If cable length between GPS Module and antenna is:

- Less than 115 meters, no line amplifier is necessary.
- More than 115 meters and less than 240 meters, you need 1 line amplifier.
- More than 240 meters and less than 360 meters, you need 2 line amplifiers.
- More than 360 meters, contact sales for assistance.

### **RG-213 Cable Line Amplifier Requirements**

If cable length between GPS Receiver and antenna is:

---

<sup>1</sup> Fifty-three point three meters includes the sum total of all of the cables used to connect the antenna to the Receiver (such as the cable between the antenna and line amplifier, the cable between the line amplifier and lightning arrester, and the cable between the lightning arrester and the Receiver.

**Inputs**

- Less than 53 meters), no line amplifier is necessary.
- More than 53 meters and less than 105 meters, you need 1 line amplifier.
- More than 105 meters and less than 158 meters, you need 2 line amplifiers.
- More than 158 meters, contact sales for assistance.

***Antenna Cable Length Delay***

The RG 213 propagation delay is 1.54 nanoseconds per foot (5.05 ns/meter). The LMR 400 propagation delay is 1.2 nanoseconds per foot (3.93  $\mu$ s/meter). Given these delay values per foot you can calculate the delay for your cable length.

Tables 2-1 and 2-2 list the delay values that you need to use with the :GPS:REFERENCE:ADELAY <seconds> command for the available cable assemblies.

**Table 2-1. Delay Values for the 58518A/519A and 58518AA/519AA RG-213 Antenna Cables**

<b>Cable Option</b>	<b>Length</b>	<b>RG 213 or Belden 8267 Antenna Delay Value</b>
001	1m	5.0 nanoseconds
002	2 m	10.3 nanoseconds
005	5 m	25.2 nanoseconds
010	10 m	50.5 nanoseconds
015	15 m	75.7 nanoseconds
030	30 m	151.5 nanoseconds
050	50 m	252.5 nanoseconds

The nominal delay value is labeled on the cables. Refer to the *Designing Your GPS Antenna System Configuration Guide* for more information.

**Inputs****Table 2-2. Delay Values for the 58520A/521A and 58520AA/521A LMR 400 Antenna Cables**

<b>Cable Option</b>	<b>Length</b>	<b>LMR 400 Antenna Delay Value</b>
001	1m	3.9 nanoseconds
002	2 m	8.0 nanoseconds
005	5 m	19.6 nanoseconds
010	10 m	39.3 nanoseconds
015	15 m	59.0 nanoseconds
030	30 m	118.0 nanoseconds
060	60 m	236.1 nanoseconds
110	110 m	432.9 nanoseconds

The nominal delay value is labeled on the cables. Refer to the *Designing Your GPS Antenna System Configuration Guide* for more information.

**Using SatStat to Correct for Delay Associated with the Antenna Cable**

It is possible to correct for the delay associated with the antenna cable, although you may not need to depending on the timing requirements of your application. If you do not correct for it, the outputs will be systematically delayed by the amount of the cable delay. Note that all outputs will be equally affected. The factory set cable delay value is 0 ns. If you want to change it, the easiest procedure is to use SatStat as described below.

- 1 To check the current antenna delay value, select **Query->Antenna Delay** from the Control & Query form. Select the **Send Cmd** control or the Enter key to send the command to check this value. After a moment, the antenna delay value will appear on the Control & Query form. As shipped from the factory, this value is 0.0 ns.
- 2 To change this value, select **Control->Antenna Delay** on the Control & Query form. Enter the amount of delay desired. For example, to set 125 ns of delay, enter 125 ns then select the enter key. After a moment, the response should be reply: command complete. The value is now set. You can confirm this by repeating step 2 or observing the ANT DLY value on the main status form (it is in the right column, row 14). NOTE: this setting is in units of seconds, not nanoseconds. However, you can terminate the command with “ns” to indicate that it should be read as nanoseconds. Thus, to set 125 ns antenna delay you can send either :GPS:REF:ADEL 125E-9 or :GPS:REF:ADEL 125 ns.
- 3 The value, once programmed, is saved even if power is lost to the Receiver.

**Inputs****POWER Input*****58503B GPS Time and Frequency Reference Receiver***

The **Power** input jack allows you to connect a 110/240 Vac, or +48 Vdc or +24 Vdc power source (depending on which power option the Receiver contains) to drive the 58503B.

Table 2-3 lists the XLR input jack pinouts. This jack is used for DC power only.

**Table 2-3. XLR Jack DC Power Connections**

Pin Number	Signal Name
1	dc supply (+)
2	dc return (-)
3	chassis ground

See Figure in Chapter 1 of this guide for illustration of the XLR jack.

***59551A GPS Measurements Synchronization Module***

The ac **Power** input jack allows you to connect 110/240 Vac power source. The 59551A can also be operated from +129 Vdc using this same ac input jack. You will need to assemble and connect a dc cable using the supplied IEC 320 dc connector plug (part number 1252-5672). See Chapter 1, "Getting Started," for instructions.

**Time Tagging Inputs (59551A Only)**

The **Time Tag 1**, **Time Tag 2**, and **Time Tag 3** BNC input connections allow you to input time tagging data to the Receiver using one of the following time tagging generators or equipment:

- Sequence of Events Recorders
- Fault Analyzers
- Phasor Measurement Units (PMUs)

The output of these devices are typically TTL pulses. The Receiver is capable of time-tagging any similar TTL rising edge.

Time tagging an event is to record the UTC time at which the rising edge reaches approximately 2.5V.

On each time-tag input, you are allowed to time tag up to 256 events for efficient fault location, network disturbance analysis, and detailed sequence-of-events analysis. The minimum time between events is 1 millisecond.

## Outputs

The resolution and time tagging features of the Receiver make it ideally suited to applications such as phasor measurement, state estimation, stability protection, and adaptive relaying.

---

## Outputs

### **1 PPS (One-Pulse-Per-Second) Output**

The Receiver outputs this highly accurate 1 PPS time standard output for user-specific synchronization applications.

In the GPS locked mode, the Receiver outputs a 1 PPS signal derived from the internal oscillator, which is locked and traceable back to Coordinated Universal Time (UTC) as determined by GPS. In the absence of GPS, the 1 PPS signal will continue to exist, but the oscillator will go into a holdover mode in which the SmartClock™ algorithm will compensate for the instabilities in the oscillator. In the holdover mode, the timing 1 PPS accuracy will degrade as the holdover time increases.

### **1 PP2S (One-Pulse-Per-Two-Seconds) Option 002 Output (58503B Only)**

This optional output provides one pulse every other second, synchronized to the even seconds in GPS time. This is the reference time used in CDMA base stations. GPS even-second pulses from the 1 PP2S option are used to synchronize the models 8921A options 600 and 601, and 6380 Cellular Base Station Test Sets. Synchronizing the test set from an independent source permits remote base station testing and independent base station frequency and time reference accuracy checks.

### **Programmable Pulse Output (59551A Only)**

This programmable pulse capability allows you to program the Receiver to output a pulse at a specific time, or a repetitive signal with a period from 1 second to 1 year.

### **IRIG-B Output (59551A Only)**

The IRIG-B123 formatted time code signal may be used for general purpose time distribution, and magnetic tape annotation applications requiring time of year.

## Outputs

IRIG-B123 is a one-frame-per-second signal indicating the date and exact time. The output contains both a BCD-coding of day, hour, minute, second, and a binary coding of accumulated seconds since midnight. An example is shown in Figure 2-1. The modulated code uses a 1 kHz carrier.

The sample IRIG-B output shown in Figure 2-1 consists of time-coded pulses that indicate the time as:

*173* days into the year,  
*21* hours into the day,  
*18* minutes into the hour, and  
*42* seconds into the minute.

The sample IRIG-B BCD output in Figure 2-1 also includes a Straight Binary portion, which consists of time-coded pulses that indicate the time of day as *76,722* seconds into the day, which is the total you would get if you summed up *21* hours, *18* minutes, and *42* seconds.

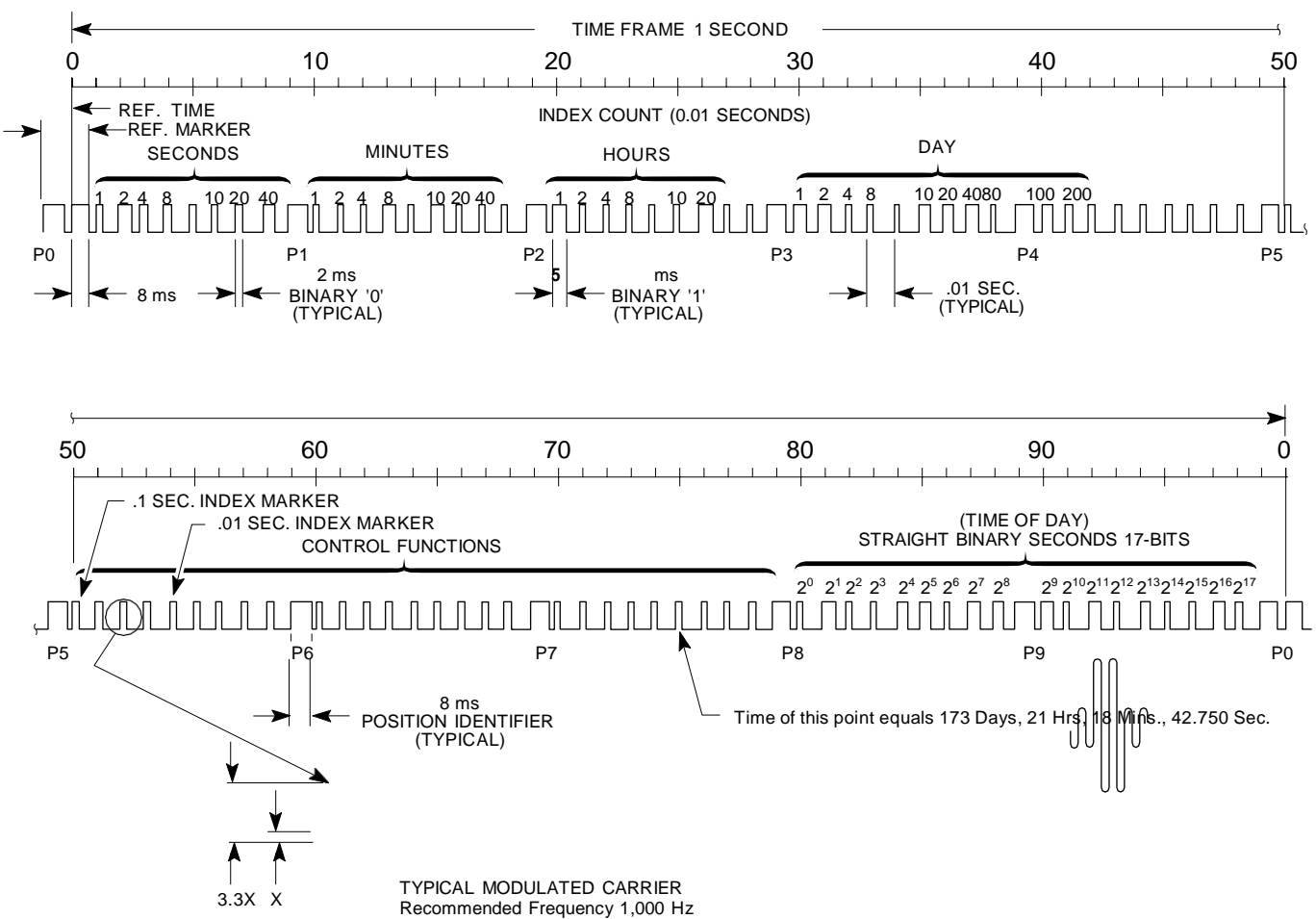

**Figure 2-1. Sample IIRIG-B Output Signal (59551A Only)**

## Outputs

### **Alarm BITE Output (59551A Only)**

When an alarm condition exists, the **Alarm BITE** (Built In Test Equipment) relay contact closes, making a closed circuit. This signal may be used to drive an external visual (e.g., red light) or audio device (e.g., horn or bell) when the Receiver detects an internal condition that requires attention.

When power to the Receiver is lost, the Alarm BITE relay contact is open (no alarm condition is indicated).

The relay opens and closes with the **Alarm** indicator. (Mating connector is Amphenol part number 31-224 [glass-filled Noryl] or #31-2226 [Telfon]).

### **Alarm Output (58503B Only)**

When an alarm condition exists, the **Alarm** output is pulled down to a TTL low. This signal may be used to drive an external visual (e.g., red light) or audio (e.g., horn or bell) device when the Receiver detects an internal condition that requires attention.

### **10 MHz OUT Output (58503B Only)**

This is a 10 MHz output reference signal traceable to UTC (USNO) that you can use as a high accuracy frequency “house standard” for calibration or development needs.

## Indicators

### Power Indicator

This indicator lights when the input power is supplied to the Receiver. The indicator cannot be set or queried via the serial interface.

### GPS Lock Indicator

This indicator lights when the Receiver has phase-locked its internal reference to a 1 PPS derived from GPS satellite signals. The outputs on the GPS Receiver — 1 PPS, Programmable Pulse Output (59951A) IRIG-B (59551A), and 10 MHz (58503B) — become usable when first lock is attained following powerup.

### Holdover Indicator

The Receiver lights this indicator when it's outputs are no longer phase-locked to the GPS reference. This can happen for several reasons, the most likely being that the antenna has been disconnected. It is also possible to force the Receiver into holdover. (Using SatStat you can do this by selecting **Control->Go to Manual Holdover** on the **Control & Query** form. To recover from manual holdover, select **Control->Recover from Manual Holdover**.)

When in holdover, the outputs are still usable, but the performance will be degraded from the locked state. The longer the holdover condition persists, the more degraded the outputs will become. If the holdover has resulted from loss of GPS satellite tracking and tracking resumes, the Receiver will automatically recover from holdover and become locked again.

---

**NOTE**

If the Holdover indicator lights before the Receiver has warmed up for 24 hours and successfully locked to GPS for 48 hours, then the Receiver has not had time to learn the characteristics of the internal reference oscillator. The specification for Timing Accuracy during holdover may not be met. This specification applies only after the Receiver has had sufficient steady-state operation time.

---

### Alarm Indicator

The Receiver lights this indicator to indicate it has detected a condition that requires attention. If the condition goes away, the indicator stays illuminated until you acknowledge it by clearing it. See the subsection "Monitoring Status/Alarm Conditions" in Chapter 5, "Command Reference," of the *58503B/59551A Operating and Programming Guide* (58503-90013) for a complete description of the Alarm Byte.

---

## Serial Interface Port(s)

The 58503B has only a rear-panel (**PORT 1**) RS-232C serial interface port.

The 59551A has separate rear-panel (**PORT 1**) and front-panel (**PORT 2**) RS-232C serial interface ports.

The rear-panel (**PORT 1**) RS-232C serial interface port is the only port which can be used to upgrade the Receiver firmware; therefore, it is referred to as the PRIMARY port. The 59551A's front-panel (**PORT 2**) RS-232C serial interface port is referred to as the SECONDARY port because it cannot be used to upgrade the Receiver firmware. The operation and configuration of these ports are described in the following paragraphs. More information is provided in the sections "Connecting a Computer or Modem" and "Configuring the RS-232C Port(s)" in this chapter on page 2-15 and page 2-20, respectively.

Either port allows you full communication with the Receiver. This can be done by connecting any computer with an RS-232C serial interface and suitable terminal emulation software, then sending the correct commands for transmitting or retrieving data.

### **PORT 1 Rear-Panel RS-232C Serial Port**

This 25-pin female subminiature D (DB-25) connector (**PORT 1**) RS-232C Serial Interface Port is located on the rear panel.

The pins used for **PORT 1** RS-232C communication are described in Table 2-4.

---

#### **NOTE**

---

We reserve the right to impose signals on other pins; therefore, your connection should be restricted to the pins described in Table 2-4.

**Table 2-4. PORT 1 Rear-Panel RS-232C Serial Port Connections**

<b>*Pin Number</b>	<b>Input/Output</b>	<b>Description</b>
2	Output	Transmit Data (TxD). GPS Receiver output.
3	Input	Receive Data (RxD). GPS Receiver input.
7	---	Signal Ground (SG)

Refer to the sections "Connecting a Computer or Modem" in this chapter, on page 2-15, for wiring diagrams and more information on the RS-232C interface cables.

**Serial Interface Port(s)****PORT 2 Front-Panel RS-232C Serial Port  
(59551A Only)**

This 9-pin female subminiature D (DE-9S) connector (**PORT 2**) RS-232C Serial Interface Port is located on the front panel.

The pins used for **PORT 2** RS-232C communication are described in Table 2-5.

**NOTE**

We reserve the right to impose signals on other pins; therefore, your connection should be restricted to the pins described in Table 2-5.

**Table 2-5. PORT 2 Front-Panel RS-232C Serial Port Connections  
(59551A Only)**

<b>*Pin Number</b>	<b>Input/Output</b>	<b>Description</b>
2	Input	Receive Data (RxD). GPS Receiver input.
3	Output	Transmit Data (TxD). GPS Receiver output.
5	—	Signal Ground (SG)

Refer to the section “Connecting a Computer or Modem” in this chapter, on page 2-15, for wiring diagrams and more information on the RS-232C interface cables.

---

## Connecting a Computer or Modem

To connect the GPS Receiver to a computer or modem, you must have the proper interface cable. Most computers are DTE (Data Terminal Equipment) devices. Since the Receiver is also a DTE device, you must use a DTE-to-DTE interface cable when connecting to a computer. These cables are also called “null-modem”, “modem-eliminator”, or “crossover” cables.

Most modems are DCE (Digital Communication Equipment) devices; thus, you must use a DTE-to-DCE interface cable.

The interface cable must also have the proper connector on each end and the internal wiring must be correct. Connectors typically have 9 pins (DE-9 connector) or 25 pins (DB-25 connector) with a “male” or “female” pin configuration. A male connector has pins inside the connector shell and a female connector has holes inside the connector shell.

**To simplify interface cable selections, the following sections tells you which cables to use.**

**Connecting a Computer or Modem**

**To Connect the GPS Receiver to a PC, Laptop, or Modem Via the Rear-Panel PORT 1**

***Connecting to the Personal Computer (PC)***

Use an HP 24542G (or equivalent) interface cable to connect the Receiver's rear-panel **PORT 1** DB-25 female connector to a PC or laptop as shown in Figure 2-2.

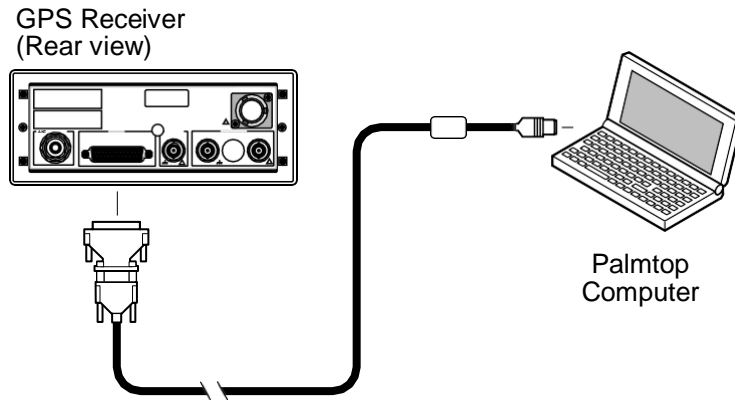
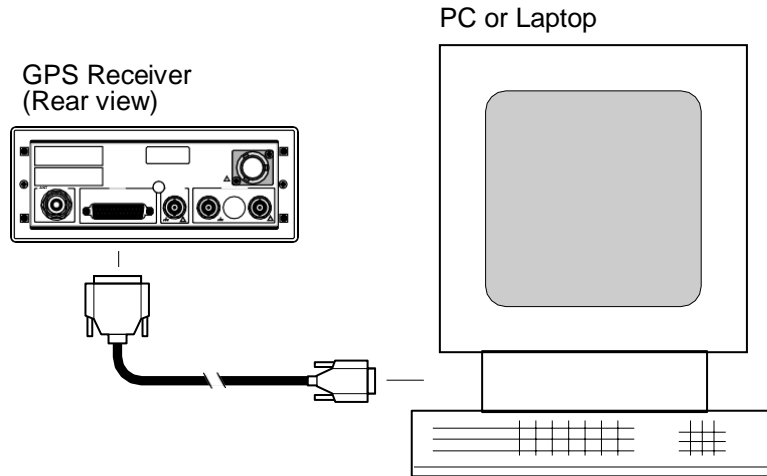

**Figure 2-2. Connecting the GPS Receiver to a PC or Laptop**

***Connecting to a Modem***

Use an HP 40242M (or equivalent) interface cable to connect the Receiver's rear-panel **PORT 1** DB-25 female connector to a modem, which is a DCE (Digital Communication Equipment) device, as shown in Figure 2-3.

Chapter 2 Features and Functions  
**Connecting a Computer or Modem**



**Figure 2-3. Connecting the GPS Receiver to a Modem**

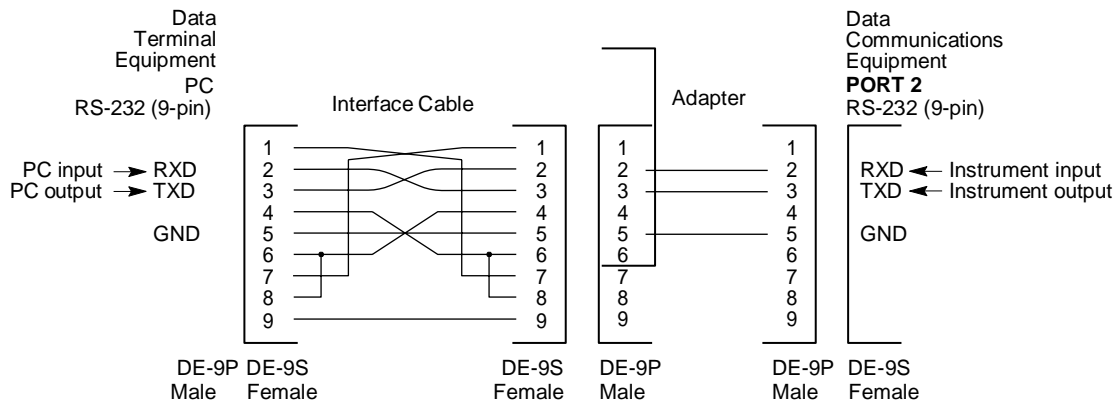

**Figure 2-4. HP 24542U (or equivalent) Interface Cable and a Straight-through Adapter Combination for Laptop and PORT 2 Connection**



## Making Your Own Cables

If you choose to make your own cable, see Figure 2-6 and Figure 2-7.

Figure 2-6 illustrates how to make a DE-9S-to-DE-9P, DTE-to-DCE interface cable that can replace the cable and adapter combination of the HP 24542U cable or equivalent and the HP 5181-6639 adapter or equivalent for use with **PORT 2** of the 59551A.

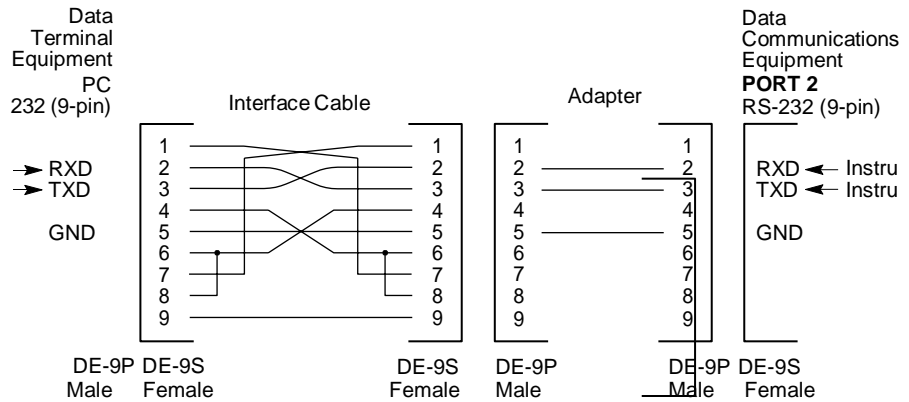

**Figure 2-6. DE-9S-to-DE-9P (DTE-to-DCE) Serial Interface Connection to PORT 2**

Figure 2-7 illustrates how to make a DE-9S-to-DB-25P, DTE-to-DTE interface cable that can replace the 25-pin male to 9-pin female connectors for use with **PORT 1**.

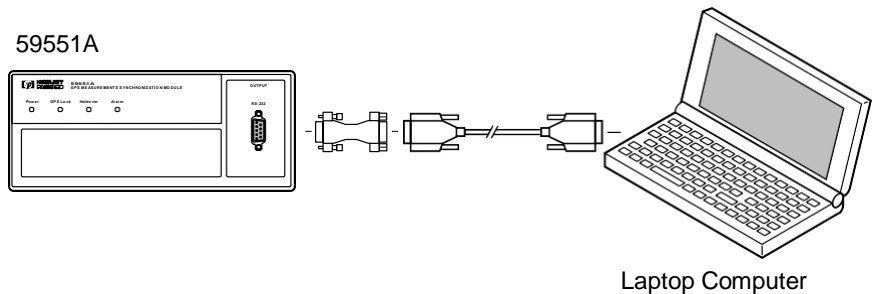

**Figure 2-7. DE-9S-to-DB-25P (DTE-to-DTE) Serial Interface Connection to PORT 1**

---

## Configuring the RS-232C Port(s)

The 59551A has separate rear-panel (**PORT 1**) and front-panel (**PORT 2**) RS-232C serial interface ports.

The 58503B has one RS-232C serial interface port (**PORT 1**) on the rear panel. **Note:** **PORT 1** of the 58503B and **PORT 2** of the 59551A have the same configuration capabilities as indicated in Table 2-7.

Software pacing, baud rate, parity, data bits, and stop bits parameters for each port are user-selectable and independent of the configuration of the other.

Table 2-6 and Table 2-7 list the configuration factory-default values for **PORT 1** and **PORT 2**.

**Table 2-6. Factory-Default Values for PORT 1 of the 59551A**

Parameter	Default	Possible Choices
Software Pacing	NONE	XON or NONE
Baud Rate	9600	1200, 2400, 9600, or 19200
Parity	NONE	EVEN, ODD, or NONE
Data Bits	8	7 or 8
Stop Bits	1	1 or 2
Full Duplex	ON	ON or OFF

**Table 2-7. Factory-Default Values for PORT 1 of the 58503B and PORT 2 of the 59551A**

Parameter	Default	Possible Choices
Software Pacing	NONE	XON or NONE
Baud Rate	9600	1200, 2400, 9600, or 19200
Parity	NONE	EVEN, ODD, or NONE
Data Bits	8	Fixed at 7 when parity is even or odd. Fixed at 8 when parity is none.
Stop Bits	1	Fixed (no choices available)
Full Duplex	ON	ON or OFF

Procedures for configuring the RS-232C ports are provided in the following paragraphs.

## Making Changes to the Serial Port Settings (If Needed)

---

**CAUTION**

*If you change the serial port settings, your changes will be stored in the Receiver. Cycling power will not reset to factory defaults. Therefore, if you make a change, it is recommended that you record the settings and keep the record with the Receiver.*

*If you need to change the serial port settings, for example, to set up for a different computer, use the guidelines given in this section.*

---

Serial port settings are changed by issuing commands.

It is recommended that you issue a single compound command which simultaneously sets all the serial port parameters. Then connect the other computer and begin using the instrument with the new settings.

---

**NOTE**

If you choose to set parameters one at a time, you will make the procedure more difficult. That is, with each change, the instrument will be updated, but your computer will retain its original settings. At each step, you will have stopped serial communications and be forced to modify your PC settings to match the Receiver in order to continue. It is recommended that you make all changes in a single compound command, verify the changes, and record all parameters.

---

### ***Configuring PORT 1 of the 59551A***

Complete configuration of **PORT 1** of the 59551A requires that you set *five* parameters. The command line sent in the following example would set the RS-232C port pacing to XON, baud rate to 2400, parity to EVEN, data bits to 7, and stop bits to 2. This command line must be transmitted on **PORT 1**.

```
SYST:COMM:SER:PACE XON; BAUD 2400; PARITY EVEN; BITS 7; SBITS 2
```

### ***Configuring PORT 1 of the 58503B and PORT 2 of the 59551A***

Complete configuration of **PORT 1** (58503B) and **PORT 2** (59551A) require that you set *three* parameters. The command line sent in the following example would set the RS-232C port pacing to XON, baud rate to 2400, and parity to EVEN. This command line must be transmitted on **PORT 1** or **PORT 2**.

```
SYST:COMM:SER2:PACE XON; BAUD 2400; PARITY EVEN
```

## **Determining the Serial Port Settings**

### ***Standard 58503B and 59551A***

If you connect your PC, press Return, and do not get a **scpi>** prompt back from the Receiver, your Receiver's serial communication settings may have been modified. You need to systematically step through the data communication settings on your PC until your PC matches the Receiver. The Receiver cannot communicate its settings until this process is complete.

Iterate until you are able to verify that settings on your PC match the Receiver.

When you are successful, you will have restored full RS-232C communications, enabling you to query the Receiver's communication settings. Once you establish communications with one serial port, you can query the Receiver for settings of either port.

Issue the following queries to either serial port to verify **PORT 1's** configuration.

```
SYST:COMM:SER:PACE?  
SYST:COMM:SER:BAUD?  
SYST:COMM:SER:PARITY?  
SYST:COMM:SER:BITS?  
SYST:COMM:SER:SBITS?
```

Issue the following queries to either serial port to verify **PORT 2's** configuration.

```
SYST:COMM:SER2:PACE?  
SYST:COMM:SER2:BAUD?  
SYST:COMM:SER2:PARITY?  
SYST:COMM:SER2:BITS?  
SYST:COMM:SER2:SBITS?
```

### ***Option 001 58503B***

To display serial port settings during initial installation for units with the Option 001 Front-Panel Display/Keypad, press the **Serial Port** key. See Chapter 3, "Using Option 001 Front-Panel Display/Keypad (58503B Only)," for more information on the Option 001.

---

## Operating Concepts

### General

The time required to acquire GPS lock as described in the following paragraph can vary significantly depending on your local conditions. In general, it is strongly recommended that your antenna and cables be set up in accordance with the information provided in this guide prior to using the output signals of the GPS Receiver to ensure they are valid.

Acquiring lock does not mean that the Receiver is fully operational and meeting all specifications. It just means that the Receiver has detected enough satellites to start its survey mode to determine its precise location. An internal measurement FFOM (Frequency Figure of Merit) becomes 0 when the internal loops reach their proper time constants, indicating that the output frequency and 1 PPS signals are now fully operational and meeting their specifications. Under the worst conditions, the Receiver may take up to 24 hours to achieve FFOM = 0. FFOM can be monitored in the Reference Outputs quadrant of the Receiver Status screen. (See Figure 3-1, in Chapter 3, “Visual User Interface,” of the *58503B/59551A Operating and Programming Guide*.) Also, using the appropriate SCPI query command will provide FFOM value (refer to the operating and programming guide for specifics).

The GPS Receiver is designed to automatically detect and acquire satellites in order to begin providing precise frequency and time information. Until such acquisition is complete and the instrument is locked with FFOM = 0, the signals produced on the rear panel are not precise. However, it is possible to verify that the Receiver has been received in good working condition by performing the operational verification test upon receipt. (See Appendix D, “Performance Tests” in the *58503B/59551A Operating and Programming Guide*.)

### Holdover Description

If the GPS signal is interrupted, the Receiver enters an intelligent holdover mode that uses SmartClock® technology. SmartClock takes over control of the quartz oscillator that has been steered to the GPS reference during locked operation. SmartClock predicts the performance of the quartz oscillator based on the information gathered during the “learning period” (locked to GPS). Corrections are automatically issued over time, keeping the performance of the quartz oscillator as close as possible to the performance achieved while locked to the GPS reference signal.

## In Case of a Problem

Holdover frequency is maintained to better than  $\pm 1 \times 10^{-10}$  per day (phase accumulation  $< 8.6 \mu\text{s}$  after 1 day). When the GPS reference signal is restored, the Receiver automatically switches back to normal mode of operation.

---

## In Case of a Problem

### Hours after powerup, Receiver not establishing GPS lock

**Symptom** Date, time, and position still show power-up defaults, or these parameters are incorrect.

Receiver Position Mode = Survey.

Receiver cycling from one set of satellites to another.

No satellites consistently tracked.

**Solution** Check antenna:

- Verify antenna has an unobstructed view of the sky—antenna is not under or beside an impervious object.
- Verify antenna is connected.
- Verify antenna is connected properly:
  - cable run not too long.
  - cable with antenna attached neither shorted nor open.
- Verify antenna is being properly driven—*Hint:* (1) Connect Tee-connector to the **ANTENNA** input; connect antenna cable to one end of Tee. Measure a little less than +5 Volts from the other end of the Tee using a digital voltmeter (DVM) as shown in Figure 2-8. If your reading is a lot less than +5 Volts, you will have to determine if the line amplifier or lightning arrester is at fault by using conventional troubleshooting isolation techniques. If the line amplifier and lightning arrester are good, then the antenna may be faulty. (2) If the Receiver's +5 Volts is okay, check +5 Volts at the antenna end of the cable with a voltmeter connected between the center conductor and shell. If insufficient voltage is present, it may indicate that the shield of the cable is not making adequate contact to one of the cable connectors.
- After the antenna connection has been verified, cycle power on the Receiver to facilitate rapid recovery from the fault.

**NOTE**

Remove the Tee connector and restore antenna connection as loading of the Tee connector will prevent proper reception of the GPS signal by the antenna.

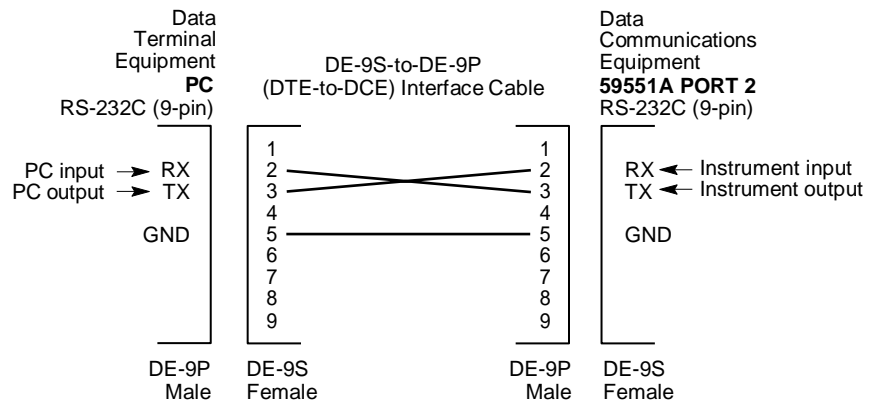

1 Tee-connector

2 DVM

**Figure 2-8. Measuring +5 Volts Across Antenna Input**

**Symptom** Same as previous symptoms, except Receiver Position Mode = Hold.

**Solution** Enable SURVEY mode using specified command.

**Receiver not maintaining GPS lock**

**Symptom** Position data incorrect.

**Solution** Survey to obtain correct position,

or

Correct position data using specified command.

**Symptom** Position data correct.

Sufficient satellites in view.

No satellites tracked.

**Solution** If candidate satellites are marked “Ignore” on status screen, disable the feature which ignores satellites.

If candidate satellites are below the mask angle specified on the Receiver Status screen, lower the elevation mask angle using the proper command. Default is 10 degrees—all satellites between the horizon and 10 degrees of the horizon are masked.

Chapter 2 Features and Functions  
**In Case of a Problem**

---

Using Option 001 Front-Panel  
Display/Keypad (58503B Only)

---

## Chapter Contents

The Option 001 front panel provides a keypad and a display for the 58503B GPS Time and Frequency Reference Receiver. This chapter presents more detailed information on the display and keypad, and is organized as follows:

- Overview page 3-3
  - About the Display and Keypad page 3-3
  - Product Compatibility page 3-3
  - System Compatibility page 3-3
- Using the Display and Keypad page 3-4
  - To Display Time page 3-4
  - To Display Position page 3-4
  - To Display Number of Satellites Being Tracked page 3-4
  - To Display Serial Port Settings page 3-5
  - To Display System Status page 3-5
  - To Clear Instrument Alarm page 3-5
- Capabilities Under Special Circumstances page 3-5
  - To Access the TEST MODE to Test the Front-Panel Display page 3-5
  - To Access the DEMO MODE to Demonstrate Front-Panel Capabilities page 3-6
  - To Check Serial Port Settings During Installation page 3-6
- Error Messages page 3-7
- Status Messages page 3-10

---

## Overview

### About the Display and Keypad

The front-panel display, shown in Figure 3-1, contains a twelve-character vacuum-flourescent display, four indicator LEDs, and eight elastomeric keys with associated mode LEDs. Each key selects a different display mode. In addition, there is one control capability (alarm clearing) available.

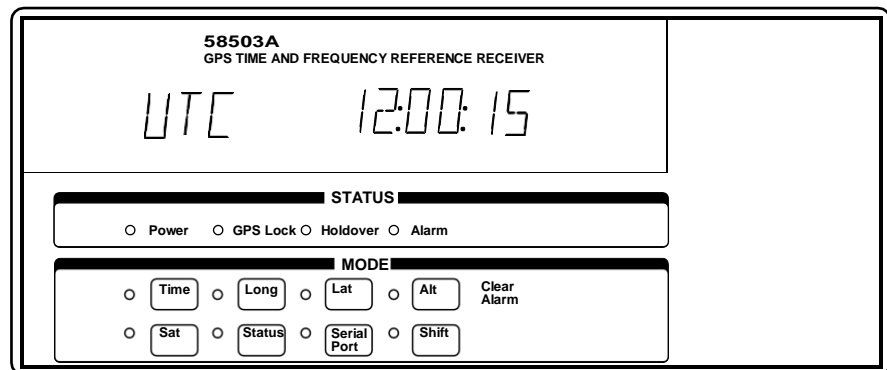

**Figure 3-1. Option 001 Front-Panel Display and Keypad**

### Product Compatibility

The Option 001 Front-Panel Display/Keypad is available as an option for the 58503B GPS Time and Frequency Reference Receiver.

### System Compatibility

Information displayed on the front panel corresponds with the same information available by other means.

Two instruments which are synchronized and racked side-by-side will increment in unison. Similarly, the instrument display will increment in unison with the SatStat® display. The display increments in unison with an IRIG decoder, and correlates with time of day outputs provided programmatically over the RS-232 interface.

## Using the Display and Keypad

### **To Display Time**

Press **Time** key to display current time.

Under special circumstances, when UTC local time is selected for use throughout the instrument, the display shows the LOCAL time. See Figure 3-1 on page 3-3.

### **To Display Position**

#### ***Displaying Longitude***

Press **Long** key to display longitude.

Following powerup, the Receiver iteratively computes its position; the longitude display is updated as computation progresses.

The longitude is displayed in the format E or W, <longitude degree>, <longitude minute>, and <longitude second>.

#### ***Displaying Latitude***

Press **Lat** key to display latitude.

Following power-up, the Receiver iteratively computes its position; the latitude display is updated as computation progresses.

The latitude is displayed in the format N or S, <latitude degree>, <latitude minute>, and <latitude second>.

#### ***Displaying Altitude***

Press **Alt** key to display altitude.

Altitude is measured in meters above the GPS ellipsoid. Following power-up, the instrument iteratively computes its position; the altitude display is updated as computation progresses.

### **To Display Number of Satellites Being Tracked**

Press **Sat** key to display a count of the number of satellites currently tracked.

## Capabilities Under Special Circumstances

### To Display Serial Port Settings

Press **Serial Port** key to display the Receiver's serial port settings.

Baud rate, parity, data bits, and stop bits settings are displayed.

### To Display System Status

Press **Status** key to display system status.

Table 3-3 lists the possible system status displays.

### To Clear Instrument Alarm

The Option 001 Front-Panel Display/Keypad allows you to clear instrument alarm.

Press and hold **Shift**, then press **Clear Alarm** (Alt) key to clear an alarm.

---

## Capabilities Under Special Circumstances

### To Access the TEST MODE to Test the Front-Panel Display

Access the product's installation TEST MODE using the following procedure.

- 1 Apply power to the 58503B. While the letters "HP" are moving from right to left (about 2 seconds), press the **Sat** key followed by the **Time** key.

If necessary, you can remove and re-connect power to re-initiate the startup and try again. When you succeed, the product will enter its VFD DSP TEST (test of the vacuum-flourescent display).

The display should first show a test pattern that sequentially illuminates all 15 segments of all digits and punctuation marks on the display. When the segment illumination is complete, the words DEMO MODE appear, and the product enters the demo mode described below.

- 2 To exit, press the **Shift** key and then press the **Alt** key.

## Capabilities Under Special Circumstances

### To Access the DEMO MODE to Demonstrate Front-Panel Capabilities

Access the product's DEMO MODE using the following procedure.

- 1 Apply power to the 58503B. While the letters "HP" are moving from right to left (about 2 seconds), press the **Shift** key.

If necessary, you can remove and re-connect power to re-initiate the startup and try again. When you succeed, the product will enter its DEMO MODE.

The DEMO MODE does not require an antenna connection. DEMO MODE was designed to support the user during demonstrations, during installation, and during initial connection to a PC.

The DEMO MODE responds to keypresses by displaying simulated data for UTC Time, Longitude, Latitude, Altitude, Satellite Count, and Status. These values are not related to the actual values, they are a simulation.

- 2 To exit the DEMO MODE, press the **Shift** key and then press the **Alt** key.

### To Check Serial Port Settings During Installation

To display Serial Port settings during initial installation, press the **Serial Port** key.

**Error Messages**

---

## Error Messages

When the instrument status system within the 58503B detects an error condition, the front-panel display will identify the error to you. Table 3-1 lists an example of message format. Table 3-2 lists error messages.

Note that errors reported on the front panel are detected and reported in the instrument status system. Detailed information is available in the *58503B/59551A Operating and Programming Guide* in Chapter 5 under the section “Monitoring Status/Alarm Conditions.” The manual is P/N 097-58503-13-iss-1. The treatment below is designed to be read in conjunction with the text and tables in Chapter 5, particularly Figure 5-1 on page 5-49 and the text following that Figure.

In addition to identifying the nature of the error detected, the front-panel display identifies which transition was detected. The status system can be configured to detect onset of conditions and/or abatement of conditions. The display identifies which has occurred. For example, the status system can be configured to detect the onset of holdover, exit from holdover, or both onset and exit. The display distinguishes these events by appending a minus (–) sign if the abatement of the condition is detected, (if a negative transition is detected). It presents a message with no appended sign if the onset of condition is detected. The holdover example in Table 3-1 describes this.

**Table 3-1. Example Message Format**

Message	Significance
<b>HOLDING</b>	Displayed when the instrument detects <i>entry</i> into Holdover. That is, the instrument detects a <i>positive transition</i> of the Holdover condition bit.
<b>– HOLDING</b>	Displayed when the instrument detects <i>exit</i> from Holdover. That is, the instrument detects a <i>negative transition</i> of the Holdover condition bit.
<b>HOLDING ?</b>	Displayed when the instrument detects either <i>entry into</i> or <i>exit from</i> Holdover. That is, the instrument detects status change, but is unable to identify whether the change is caused by either a <i>positive transition</i> or a <i>negative transition</i> of the Holdover condition bit.

**Table 3-2. Error Messages \***

<b>Displayed Message</b>	<b>Meaning</b>	<b>Corresponding Status Register</b>	<b>Bit</b>
<b>1ST SAT AQ</b>	first satellite has been tracked	Powerup	0
<b>OXCO WARM</b>	internal oscillator warmed up	Powerup	1
<b>DT TM VALD</b>	date and time have become valid	Powerup	2
<b>HOLDING</b>	user-initiated holdover entered	Holdover	0
<b>RCOVR WAIT</b>	instrument-initiated holdover entered, waiting to recover	Holdover	1
<b>RECOVERING</b>	recovering from holdover	Holdover	2
<b>THRESH EXD</b>	holdover duration exceeds threshold	Holdover	3
<b>SLFTST ERR</b>	selftest error	Hardware	0
<b>POS 15V ER</b>	+15-volt supply voltage exceeds tolerance	Hardware	1
<b>NEG 15V ER</b>	-15-volt supply voltage exceeds tolerance	Hardware	2
<b>POS 5V ER</b>	+5-volt supply voltage exceeds tolerance	Hardware	3
<b>OVEN TOLER</b>	Oven supply exceeds tolerance	Hardware	4
<b>EFC NR LMT</b>	EFC, (oscillator electronic frequency control voltage) near full-scale	Hardware	6
<b>EFC LIMIT</b>	EFC voltage at full-scale	Hardware	7
<b>GPS PPS ER</b>	Invalid GPS-engine 1 PPS signal	Hardware	8
<b>GPS FAILED</b>	GPS engine not communicating	Hardware	9
<b>TI MEAS ER</b>	Measurement engine failed	Hardware	10
<b>PROM WR ER</b>	Failure during write to non-volatile memory hardware	Hardware	11
<b>INT REF ER</b>	Internal 1 PPS reference failure	Hardware	12
<b>QUERY ERR</b>	Query error	Command Error	2
<b>HW-FMW ERR</b>	Hardware/Firmware Error	Command Error	3
<b>SEMANT ERR</b>	Semantic Error	Command Error	4
<b>SYNTAX ERR</b>	Syntactic Error	Command Error	5
<b>PWR CYCLD</b>	Power cycled. Set at powerup	Command Error	7
<b>PWERUP SUM</b>	Power-up status summary bit	Operation	0
<b>LOCKED</b>	Locked to GPS	Operation	1
<b>HLDOVR SUM</b>	Holdover status summary bit	Operation	2

**Error Messages****Table 3-2. Error Messages \* (continued)**

<b>Displayed Message</b>	<b>Meaning</b>	<b>Corresponding Status Register</b>	<b>Bit</b>
<b>POS HOLD</b>	Position Hold	Operation	3
<b>PPS RF VLD</b>	1 PPS reference valid	Operation	4
<b>HRDW SUM</b>	Hardware status summary bit	Operation	5
<b>LOG NR FUL</b>	Diagnostic Log almost full	Operation	6
<b>TIME RESET</b>	Receiver reset its time	Questionable	0
<b>USER EVENT</b>	User sets this bit manually	Questionable	1
<b>QUES SUM</b>	Questionable register summary bit	Status Byte	3
<b>CMD ER SUM</b>	Command Err register summary bit	Status Byte	5
<b>MSTR SUM</b>	Master summary bit	Status Byte	6
<b>OPER SUM</b>	Operation register summary bit	Status Byte	7

\* When the **Alarm** LED is illuminated by an error condition, the instrument display will show the cause of the alarm. Until the alarm is cleared, the displayed alarm (error) message will have priority over any other message on the display. For example, instead of displaying time, even if the **Time** key is pressed, the instrument will display the alarm (error) message.

## Status Messages

# Status Messages

The instrument provides several messages on the front-panel display which report routine operation. These are not messages originating from the Status/Alarm system. They are progress reports intended to provide a general indication of instrument state. The messages and their meanings are tabulated in Table 3-3.

**Table 3-3. Status Messages**

Displayed Message	When Message Appears	Meaning
<b>TIME: **.**.**</b>	Following powerup, before valid data is computed	Time key pressed, data not yet valid
<b>LAT: **.**.** *</b>	Following powerup, before valid data is computed	Latitude key pressed, data not yet valid
<b>LONG: **.**.** *</b>	Following powerup, before valid data is computed	Longitude key pressed, data not yet valid
<b>ALT: +**.**m</b>	Following powerup, before valid data is computed	Altitude key pressed, data not yet valid
<b>UTC &lt;numerics&gt;</b>	During normal operation, on keypress	Current UTC time, uncorrected for local time zone offset
<b>LOCAL &lt;numerics&gt;</b>	During normal operation, on keypress	Current UTC time, corrected for local time zone offset
<b>&lt;LAT numerics&gt;</b>	During normal operation, on keypress	Latitude
<b>&lt;LONG numerics&gt;</b>	During normal operation, on keypress	Longitude
<b>&lt;ALT numerics&gt;</b>	During normal operation, on keypress	Altitude, meters above the GPS ellipsoid
<b>x TRACKED</b>	During normal operation, on keypress	Number of satellites currently being tracked
<b>&lt;baud&gt;, &lt;parity&gt;, &lt;data bits&gt;, &lt;stop bits&gt;</b>	During normal operation, on keypress	Current serial port settings (displayed in order shown)
<b>ALARM CLEARED</b>	On keypress sequence: Shift followed by Alarm Clear	Instrument alarms have been cleared
<b>NO ALARM</b>	On keypress sequence: Shift followed by Alarm Clear	Alarm clear was requested, no alarm condition was detected.
<b>58503B</b>	Powerup	Product identification. To enter demo mode, hit shift as this message scrolls.
<b>OEXO WARM UP</b>	Normal warmup	Oscillator warming up

**Table 3-3. Status Messages (continued)**

<b>Displayed Message</b>	<b>When Message Appears</b>	<b>Meaning</b>
<b>SAT AQUIRD</b>	Normal warmup	Number of satellites currently being tracked
<b>COARSE F ADJ</b>	Normal warmup	Coarse frequency adjustment
<b>FINE F ADJ</b>	Normal warmup	Fine frequency adjustment
<b>PHASE ALIGN</b>	Normal warmup	Phase alignment
<b>LEAPSEC CALC</b>	Normal warmup	Leapsecond adjustment
<b>OUTPUT VALID</b>	Normal warmup	Outputs valid
<b>STABILIZING</b>	Normal operation	FFOM equal to 1
<b>10MHZ STABLE</b>	Normal operation	FFOM equal to 0
<b>SURV &lt;numeric&gt; PCT</b>	Normal warmup	Survey for position has progressed to stated percent completion.
<b>&lt;numeric&gt; HLD USR</b>	Holdover	Holdover has been manually initiated by the user. Holdover duration is specified <numeric>. Note if <numeric> exceeds 99:59, the label MAX appears.
<b>&lt;numeric&gt; HLD LIM</b>	Holdover	Holdover initiated when time error between internal and external 1 PPS signals exceeded limit. Holdover duration is specified <numeric>. Note if <numeric> exceeds 99:59, the label MAX appears.
<b>&lt;numeric&gt; HLD GPS</b>	Holdover	Holdover initiated on loss of GPS satellites. Holdover duration is specified <numeric>. Note if <numeric> exceeds 99:59, the label MAX appears.
<b>&lt;numeric&gt; HOLDOVER</b>	Holdover	Holdover for reasons other than those identified above. Usually on transition out of user-initiated holdover.
<b>HLD RECVR</b>	Recovering from Holdover	Recovering from holdover
<b>FINE F ADJ</b>	Recovering from Holdover	Recovering from holdover, fine frequency adjustment
<b>PHASE ALIGN</b>	Recovering from Holdover	Recovering from holdover, phase alignment

**Status Messages**



## Specifications and Characteristics

The specifications and characteristics of the 58503B GPS Time and Frequency Reference Receiver are provided in this chapter.

### **GPS Receiver Features**

Eight-channel, parallel tracking GPS engine

C/A Code, L1 Carrier

SmartClock™ technology

Enhanced GPS technology

# Chapter 4 58503B Specifications

## Specifications and Characteristics

### 10 MHz Output

#### Specifications

##### Locked:

Frequency Accuracy: Better than  $1 \times 10^{-12}$ , for a one-day average, 0° C to 50° C.

##### Unlocked:

Holdover aging:  
 $<1 \times 10^{-10}$  per day average  
 frequency change in 24 hours of  
 unlocked operation. (See Note 1.)

##### Phase Noise: (Locked)

Offset From Signal (Hz)	SSB Phase Noise (dBc)
1	-85
10	-125
100	-135
1000	-140
10000	-145

##### Time Domain Stability: (Locked) (See graph on next page.)

Averaging Time Seconds	Root Allan Variance
0.01	$1.5 \times 10^{-10}$
0.1	$1.5 \times 10^{-11}$
1	$5 \times 10^{-12}$
10	$5 \times 10^{-12}$
100	$5 \times 10^{-11}$
1000	$5 \times 10^{-11}$

#### Supplemental Information

- Waveform: Sine wave
- Amplitude: >1 volt p-p into a 50Ω load
- Harmonic Distortion: <-25 dBc (Typical)
- Non-harmonic signals: <-60 dBc (Typical)
- Source impedance: 50Ω (nominal)
- Coupling: ac
- Connector: BNC

#### Note 1

This specification has a 95% probability, and is based on the availability of four or more GPS satellites during three days of locked operation with a fixed antenna location. The temperature must remain within a 10° C range between 10° C and 40° C.

#### Note 2

When a quartz crystal oscillator has not been operated for a period of time, or if it has been subjected to severe thermal or mechanical shock, as might be encountered during product shipment, the oscillator may take some time to stabilize. In most cases, the oscillator will drift and then stabilize at or below its specified rate within a few days after being turned on. In isolated cases, depending upon the amount of time the oscillator has been off and the environmental conditions it has experienced, the oscillator may take up to one week to reach its specified aging rate and to operate without significant frequency "jumps."

When a Hewlett-Packard GPS Receiver is initially turned on and locked to the GPS satellite system, it will achieve GPS lock within 30 minutes of operation. It has a 95% probability of meeting unlocked (holdover) specifications after 24 hours of warmup, followed by GPS locked for 48 hours. The longer GPS Receiver (and its quartz oscillator) operates, the better its stability and unlocked (holdover) performance becomes.

### 1 PPS Output

#### Specifications

##### Locked:

Jitter of leading edge: <750 ps rms with at least one satellite in view, SA on.

##### Time Accuracy:

<110 ns with respect to UTC (USNO MC)—95% probability when unit is properly installed, calibrated, and locked to GPS.

##### Unlocked:

Accumulated time error: <8.6 μs accumulated in 24 hours of unlocked operation. (See Note 1.)

#### Supplemental Information

- Pulse Width: 26 μsec
- Amplitude: >2.4 volts into 50Ω load. (TTL compatible)
- Connector: BNC
- Rise time: <25 ns

### Additional Features

**Alarm Output:** TTL open collector with internal pull-up resistor.

Circuit can sink up to 10 ma. Provides a logic output to allow monitoring of normal (H) and abnormal (L) operation externally and remotely. BNC connector.

#### Front Panel Indicators (LEDs):

Power  
 GPS Lock  
 Holdover Mode  
 Alarm

#### Remote Interface:

RS-232-C DTE configuration:  
 Complete remote control and interrogation of all instrument functions and parameters.

Factory defaults: baud rate 9600, 8 data bits, 1 start bit, 1 stop bit, no parity. Other settings are programmable.

**Connector:** 25-pin female rectangular D subminiature on rear panel.

Time code output is available to a computer immediately preceding the 1 PPS signal for the current second.

### Environmental Specifications

#### Time and Frequency Reference Receiver (58503B)

Operating: 0° C to +50° C  
 Storage: -40° C to +80° C

#### Antenna (58532A)

Operating: -30° C to +80° C  
 Storage: -40° C to +85° C

Chapter 4 58503B Specifications  
Specifications and Characteristics

**Power Requirements**

**AC Power (standard):**

90 to 132 Vac or 198 to 264 Vac,  
automatically selected;  
50 to 60 Hz.

**Option AWQ:**

Unit accepts:  
+24 Vdc or + 48 Vdc nominal.  
Actual operating range:  
+19 to +60 Vdc operating range.  
Greater than  
+23 Vdc required to start.

**Input Power (all options):**

<35 watts (nominal).

**Weight and Size**

**Dimensions:**

88.5 mm H ×  
212.6 mm W × 348.3 mm D.  
Half-Rack Module

**Weight:** 3.6 kg (8 lbs).

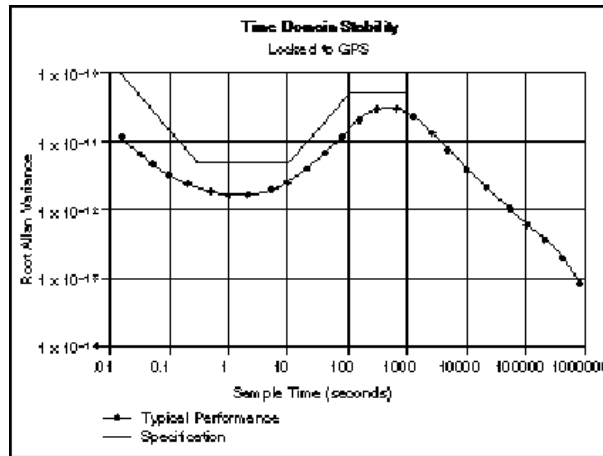

10 MHz Root Allan Variance

## **Specifications and Characteristics**

### **Other Information**

The standard 58503B does not include a display or a keypad. While not necessary, it may be convenient to track the Receiver's progress during installation and startup by monitoring the satellites being tracked, location (position), time and other parameters. The 58503B, however, is supplied with a small Windows 3.1 program named SatStat (59551-13401), which can serve to display important parameters. SatStat operates on any PC that can run Windows 3.1, and that has an available serial interface.

SatStat provides several useful functions. It continuously polls the RS-232C interface and displays Receiver information most likely to be of interest. This includes satellites being tracked along with their elevation and azimuth, SmartClock State (locked, holdover, etc.), antenna coordinates, time and frequency figures of merit and other data. In addition, a clock window is provided to display time of day in real time. Finally, SatStat allows you to easily change many receiver parameters, such as antenna delay, by simply picking the item from a pop-up menu and entering a new value. With SatStat and a PC, you can monitor and control many aspects of the Receiver status without developing software.

Achieving accurate time of day requires care in determining cable delays, Receiver bias, position (Lat, Lon, Alt), atmospheric conditions and other parameters which are dependent on each individual installation.

### **Options and Accessories**

Available options and accessories include an antenna, an antenna environmental cover and ground plane, pre-configured cables, a lightning arrester, an antenna line amplifier, a built-in display and dc power. Ask your representative for a copy of the 58503B price list, which included additional pricing and ordering information.

Chapter 4 58503B Specifications  
**Specifications and Characteristics**



## Specifications and Characteristics

The specifications and characteristics of the 59551A GPS Measurements Synchronization Module are provided in this chapter.

### **GPS Receiver Features**

Eight-channel, parallel tracking GPS engine  
C/A Code, L1 Carrier  
SmartClock™ technology  
Enhanced GPS technology

# Chapter 5 59551A Specifications

## Specifications and Characteristics

### 1 PPS Output

#### Specifications

##### Locked:

Jitter of leading edge: <750 ps rms with at least one satellite in view.

##### Time Accuracy:

<110 ns with respect to UTC (USNO MC)—95% probability when unit is properly installed, calibrated, and locked to GPS.

##### Unlocked:

Accumulated time error: <8.6  $\mu$ s accumulated in 24 hours of unlocked operation. (See Note 1.)

#### Supplemental Information

- Pulse Width: 26  $\mu$ sec
- Amplitude: >2.4 volts into 50 $\Omega$  load. (TTL compatible)
- Connector: BNC
- Rise time: <5 ns

### Additional Features

#### Alarm BITE Output:

Basic unit output: solid state relay (normally open); closed contact indicates system fault or loss of satellite lock. Contact rating 200 Vdc @ 0.5 amps.

Connector: Twin BNC

#### IRIG-B123 Output Port

BNC connector

##### Note 1

This specification has a 95% probability, and is based on availability of four or more GPS satellites during three days locked operation with a fixed antenna location. The temperature must remain within a 10° C range between 10° C and 40° C.

##### Note 2

When a quartz crystal oscillator has not been operated for a period of time, or if it has been subjected to severe thermal or mechanical shock, as might be encountered during product shipment, the oscillator may take some time to stabilize. In most cases, the oscillator will drift and then stabilize at or below its specified rate within a few days after being turned on. In isolated cases, depending upon the

amount of time the oscillator has been off and the environmental conditions it has experienced, the oscillator may take up to one week to reach its specified aging rate and to operate without significant frequency "jumps."

When a GPS Receiver is initially turned on and locked to the GPS satellite system, it will achieve GPS lock within 30 minutes of operation. It has a 95% probability of meeting unlocked (holdover) specifications after 24 hours of warmup, followed by GPS locked for 48 hours. The longer GPS Receiver (and its quartz oscillator) operates, the better its stability and unlocked (holdover) performance becomes.

#### Three Time-tag Inputs

Received signal: TTL, 50 $\Omega$ .  
Time-tag accuracy: same as the accuracy of the 59551A.  
Quantization: 100 ns  
Input Interface: BNC  
Minimum Pos/Neg pulse width: 200 ns  
Three time-tag buffers: 256 events each, retrievable via RS-232C.  
Minimum time between events: 1 ms  
Maximum stamp rate: 1 measurement per ms

#### Timer/Clock Output

Programmable Pulse Output:  
Single pulse at the time programmed via RS-232C port, or repetitive output pulse at a programmable repetition period from 1 second to 1 year.  
Quantization: 100 ns  
Accuracy: same as the time accuracy of the 59551A.

#### Front Panel Indicators (LEDs):

Power  
GPS Lock  
Holdover Mode  
Alarm

#### Remote Interface: (Two RS-232C Ports)

RS-232-C DTE configuration:  
PRIMARY PORT

Complete remote control and interrogation of all instrument functions and parameters.

SECONDARY PORT

Interrogation of all instrument functions and parameters.

Factory defaults: baud rate 9600—8 data bits, 1 start bit, 1 stop bit, no parity. Other settings are programmable.

Connectors: 9-pin female rectangular D subminiature (DB-9) on front panel, 25-pin female rectangular D subminiature (DB-25) on rear panel.

Time code output is available to a computer immediately preceding the 1 PPS signal for the current second.

## Specifications and Characteristics

### **Environmental Specifications**

#### **Measurements Synchronization Module (59551A)**

Operating: 0° C to +50° C

Storage: -40° C to +80° C

#### **Antenna (58532A)**

Operating: -40° C to +80° C

Storage: -40° C to +85° C

### **Power Requirements**

#### **AC Power:**

90 to 132 Vac or 198 to 264 Vac, automatically selected;  
50 to 60 Hz.

or

#### **DC Power:**

129 Vdc nominal (115 to 140 Vdc operating range).

#### **Input Power (all options):**

<35 watts (nominal).

### **Weight and Size**

#### **Dimensions:**

88.5 mm H × 212.6 mm W × 348.3 mm D. Half-Rack Module

**Weight:** 3.6 kg (8 lbs).

#### **Surge Withstand:**

Meets IEEE/ANSI C37.90, C37.90.1

## **Specifications and Characteristics**

### **Other Information**

The standard 59551A does not include a display or a keypad. While not necessary, it may be convenient to track the Receiver's progress during installation and startup by monitoring the satellites being tracked, location (position), time and other parameters. The 59551A, however, is supplied with a small Windows 3.1 program named SatStat (59551-13401), which can serve to display important parameters. SatStat operates on any PC that can run Windows 3.1, and that has an available serial interface.

SatStat provides several useful functions. It continuously polls the RS-232C interface and displays Receiver information most likely to be of interest. This includes satellites being tracked along with their elevation and azimuth, SmartClock State (locked, holdover, etc.), antenna coordinates, time and frequency figures of merit and other data. In addition, a clock window is provided to display time of day in real time. Finally, SatStat allows you to easily change many receiver parameters, such as antenna delay, by simply picking the item from a pop-up menu and entering a new value. With SatStat and a PC, you can monitor and control many aspects of the Receiver status without developing software.

Achieving accurate time of day requires care in determining cable delays, Receiver bias, position (Lat, Lon, Alt), atmospheric conditions and other parameters which are dependent on each individual installation.

### **Options and Accessories**

Available options and accessories include an antenna, an antenna environmental cover and ground plane, pre-configured cables, a lightning arrester, an antenna line amplifier, a built-in display and ac power. Ask your representative for a copy of the 59551A price list, which included additional pricing and ordering information.

Chapter 5 59551A Specifications  
**Specifications and Characteristics**

---

# Index

## NUMERICS

1 PPS, 1-4  
1 PPS output, 1-6  
1 PP2S connector (optional), 1-4, 2-8  
1 PP2S output, 1-4, 2-8  
10 MHz OUT, 1-4  
10 MHz output, 2-11

## A

ac power, 1-6, 1-8  
accessories  
    available, x  
    supplied, x  
acquiring GPS lock, 2-23  
Alarm, 1-2, 1-4  
Alarm BITE, 1-6  
alarm clearing, 3-5  
Alarm condition, viii, ix, 1-2, 1-4, 1-5  
Alarm indicator, 1-6, 2-11, 2-12  
Alarm LED, 1-3  
altitude display, 3-4  
ANT (antenna) connector, 2-4  
antenna, 2-4  
    assembling, 1-7  
    cable length delay, 2-5  
    delay values, 2-5  
    installation, 1-7  
    propagation delay, 2-5  
antenna cable, x, 2-4  
antenna cables, xi  
ANTENNA connector, 1-4, 1-6  
antenna connector, 2-4  
Antenna Line Amplifier, x  
antenna, operation without, 3-6  
antenna, reference, x, 2-4  
arrestor  
    lightning, x

## B

bandpass filter, x  
base stations, 2-8  
baud, 2-20  
baud rate, 2-20  
BAUD-rate setting, 3-5, 3-6  
Belden  
    8267 cable, 2-4

## C

cable  
    antenna, x, xi, 2-4  
    interconnect, antenna, x, xi  
    LMR†400, 2-4  
    recommended, 2-4  
    RG-213, 1-7

    RG213, 2-4  
cable assemblies, 2-4  
cable length delay, 2-5  
cables, 2-5  
    crossover, 2-15  
    HP 58521AA, xi  
    HP 24542G interface, 2-16  
    HP 24542U, 2-19  
    HP 40242M interface, 2-16  
    HP 58518A, x  
    HP 58518AA, xi  
    HP 58519A, x  
    HP 58519AA, xi  
    HP 58520A, xi  
    HP 58520AA, xi  
    HP 58521A, xi  
    modem-eliminator, 2-15  
    null-modem, 2-15  
CDMA base stations, 2-8  
characteristics  
    58503B, 4-2  
    59551A, 5-2  
clearing alarm, 3-5  
commands, 1-21  
commands, SCPI, 1-21  
communication  
    serial interface port, 2-13, 2-14  
compatibility, 3-3  
compensate for antenna cable delay, 1-22  
computer  
    PC, 1-12  
    terminal, 1-12  
concepts  
    operating, 2-23  
configuration  
    PORT 1, 2-22  
    PORT 2, 2-22  
configuration guide, 1-7  
configuring PORT 1, 2-21  
configuring PORT 2, 2-21  
configuring serial port, 1-13  
configuring the RS-232C ports, 2-20  
connecting a computer, 2-15  
connecting a laptop, 2-16, 2-18  
connecting a modem, 2-15, 2-16  
connecting a PC, 2-16  
connecting to computer, 1-9, 1-12  
connecting to terminal, 1-12  
connectors  
    antenna, 2-4  
Coordinated Universal Time (UTC), 2-8  
crossover cable, 2-15  
customizing installation, 1-21

customizing the Receiver operation, 1-20

## D

data bits, 2-20  
 DB-25 connector, 2-15  
 DB-9 connector, 2-15  
 dc power, 1-6, 1-8, 1-9  
 dc power connections, 2-7  
 DCE, 2-15  
 default values, 1-13, 1-14  
 defaults, factory settings, 2-20  
 delay value, 2-5  
 delay values, 2-5  
 demo mode, 3-6  
 description  
   holdover, 2-23  
 description of HP 58503A, viii  
 description of HP 59551A, ix  
 difficulty  
   in case of a problem, 2-24  
 display, 3-3  
 display/keypad, 3-1  
 DTE, 2-15

## E

elevation mask angle, 1-23  
 error messages, 3-7  
 example commands, 1-21

## F

factory default settings, 2-20  
 Fault Analyzers, 2-7  
 FFOM (Frequency Figure of Merit), 2-23  
 filter, bandpass, x  
 firmware installation, 2-13  
 firmware revision code, 2-13  
 firmware upgrade, 2-13  
 front panel  
   HP 59551A, 1-5  
   PORT 2, 2-14  
 front-panel display/keypad, 3-3  
 front-panel display/keypad, 3-1  
 full duplex, 2-20

## G

Getting Started Guide, xii  
 GPS ANTENNA input, 2-4  
 GPS Lock, 1-2  
 GPS Lock indicator, 2-12  
 GPS Lock LED, 1-3, 1-5  
 GPSaccessories, x

## H

height, 1-24  
 help from HP, 1-7, 2-4, 2-5  
 Holdover, 1-2  
 holdover, 2-12  
 holdover description, 2-23

Holdover indicator, 2-12  
 Holdover LED, 1-3, 1-5  
 holdover mode, viii, ix, 1-2, 1-5  
 HP 58503B Receiver, viii  
 HP 58518A cable, x  
 HP 58518A/519A cable, 2-5  
 HP 58518AA cable, xi  
 HP 58518AA/519AA cable, 2-5  
 HP 58519A cable, x  
 HP 58519AA cable, xi  
 HP 58520A cable, xi  
 HP 58520A/521A cable, 2-6  
 HP 58520AA cable, xi  
 HP 58520AA/521AA cable, 2-6  
 HP 58521A cable, xi  
 HP 58521AA cable, xi  
 HP 59551A Receiver, ix, 1-6  
 HP SatStat  
   operating, 1-19  
 HP Satstat Program, 1-18  
 HP 24542G interface cable, 2-16  
 HP 24542U cable, 2-19  
 HP 40242M interface cable, 2-16  
 HP 58529A antenna line amplifier, x  
 HP 58530A GPS L1 bandpass filter, x  
 HP 58532A L1 Reference Antenna, x, 2-4  
 HP 58538A lightning arrester, x  
 HP 58539A lightning arrester, x  
 HP SatStat Program, x

## I

I/O  
   PORT 1, HP 59551A, 1-6  
   PORT 2, HP 59551A, 1-5  
 in case of a problem, 2-24  
 indicator  
   Alarm, 1-2, 1-5, 1-6, 2-11, 2-12  
   COASTING, 2-12  
   GPS Lock, 1-2, 1-5, 2-12  
   Holdover, 1-2, 1-5  
   Power, 1-2, 1-5, 2-12  
 indicators, 2-12  
   Alarm, 1-3  
   GPS Lock, 1-3  
   Holdover, 1-3  
   Power, 1-3  
 input  
   antenna, 1-6, 2-4  
   Power, 1-4  
   Time Tag, 1-6, 2-7  
 input jack, 1-6  
 inputs  
   Time tag, 1-6  
 install  
   firmware, 2-13  
 installation

## Index

- antenna, 1-7
- instrument state, 3-10
- interconnect cables, x, xi
- interface
  - RS-232C, 2-13
- IRIG-B, 2-8
- IRIG-B output, 1-6
- IRIG-B output signal, 2-10
- K**
- keypad, 3-1, 3-3
- L**
- L1 bandpass filter, x
- laptop, connection, 2-18
- latitude, 1-24
- latitude display, 3-4
- LED
  - Alarm, 1-2, 1-3, 1-5, 1-6, 2-11, 2-12
  - GPS Lock, 1-2, 1-3, 1-5, 2-12
  - Holdover, 1-3, 1-5, 2-12
  - Power, 1-2, 1-3, 1-5, 2-12
- Light-Emitting-Diode, viii, ix
- lightning arrestor, x
- line amplifier, x
- line amplifier requirements, 2-4
- list of accessories, x
- list of options, x
- LMR cables, 1-7
- LMR 400 cable, 2-4
- local time, 1-23
- longitude, 1-24
- longitude display, 3-4
- M**
- manuals, xii
  - getting started, xii
  - operating and programming, xii
- Measurements Synchronization
  - Module, ix
- modem-eliminator cable, 2-15
- N**
- null-modem cable, 2-15
- O**
- One-Pulse-Per-Second, 2-8
- One-Pulse-Per-Two-Second, 2-8
- Operating and Programming Guide, xii
- operating concepts, 2-23
- Option 001 Display/Keypad, x
- Option 001, Display/Keypad, 3-1, 3-3
- Option 002 1 PPS2 Output, x
- Option 002 1 PPS2, 2-8
- Option 1CM Rack Mount, x
- Option AWR Power Supply, x
- Option AXB Rack Mount, x
- options, x
- output
  - 1 PPS, 1-4, 1-6, 2-8
  - 10 MHz, 2-11
  - 10 MHz OUT, 1-4
  - Alarm, 1-4, 2-11
  - Alarm BITE, 1-6, 2-11
  - IRIG-B, 1-6, 2-8
  - Programmable Pulse, 1-6
  - programmable pulse, 2-8
- outputs, 2-8
  - 1 PPS (optional), 1-4, 2-8
  - 1 PPS, 1-6
  - IRIG-B, 1-6
  - Programmable Pulse, 1-6
- P**
- pace, 2-20
- parity, 2-20
- Phasor Measurement Units (PMUs), 2-7
- pin assignment
  - PORT 1, 2-13
  - PORT 2, 2-14
- plug, XLR, 1-8
- PORT, 1-6
  - PORT 1, 2-16
    - factory-default values, 2-20
  - PORT 1 configuration, 2-22
  - PORT 1 rear panel, 2-13
  - PORT 1, HP 58503A, 1-4
  - PORT 2, 1-5
    - factory-default values, 2-20
  - PORT 2 configuration, 2-22
  - PORT 2 front panel, 2-14
- position survey, 1-22
- Power, 1-2
- power
  - ac, 1-6, 1-8
  - dc, 1-6
  - dc (58503B), 1-8
  - dc (59551A), 1-9
- Power indicator, 2-12
- POWER input, 1-4
- power input jack, 1-6
- Power input jack, HP 58503A, 1-4
- Power LED, 1-3, 1-5
- power supply, 1-6
- powering up the Receiver, 1-15
- power-up messages, 3-10
- power-up procedure, 1-15
- Preparing for Use, 1-7
- preset to factory defaults, 2-20
- programmable pulse, 2-8
- Programmable Pulse output, 1-6
- propagation delay, 2-5
- R**
- rear panel

## Index

- HP 58503A, 1-4
- HP 59551A, 1-6
- PORT 1, 2-13
- Receiver Status Screen, 1-17
- reference antenna, HP 58532A, x, 2-4
- reset to factory defaults, 2-20
- restore to factory defaults, 2-20
- RG213 cable, 2-4
- RG-213 cables, 1-7
- RS-232 cables supplied, 1-7
- RS-232 default values, 1-13, 1-14
- RS-232 port
  - configuring, 1-13, 1-14
  - setting, 1-13, 1-14
- RS-232C, 1-4, 1-5, 1-6
- RS-232C ports, 2-13

### S

- sample status screen, 1-18
- SatStat Program, x, 1-18
- SCPI commands, 1-21
- screen
  - status, 1-17
- self test, 1-16
- self-test diagnostics, 1-16
- Sequence of Events Recorders, 2-7
- serial interface, 1-4, 1-5, 1-6
- serial interface port, 2-13, 2-14
- serial port
  - configuring, 1-13, 1-14
  - setting, 1-13, 1-14
- serial port settings, 2-22
- settings, serial port, 2-22
- software pacing, 2-20
- specifications
  - 58503B, 4-2
  - 59551A, 5-2
- status display, 3-5
- status messages, 3-10
- status reference documentation, 3-7
- Status Screen, 1-17
- status screen, 1-18
- steady-state operation, 1-15
- stop bits, 2-20
- survey using command, 1-22
- surveying, 1-22
- SYSTEM:
  - PRESET command, 1-21
  - STATUS?, 1-16
  - STATUS? command, 1-16

### T

- terminal emulation program, 1-12
- test mode, 3-5
- Time and Frequency Reference
  - Receiver, viii
- time display, 3-4

- Time tag inputs, 1-6
- time tagging generators, 2-7
- Time Tagging Inputs, 2-7
- time zone, 1-23
- time, local, 1-23
- tracking satellites, 1-15
- troubleshooting, 2-24

### U

- upgrading firmware, 2-13
- UTC, 2-8
- UTC (USNO), 2-11
- UTC time, 1-23

### W

- Windows, 1-16
- Windows application
  - HP SatStat Program, 1-18

### X

- XLR plug, 1-8

### Z

- zone, time, 1-23